

Rural Water Supply

Introductory Level Training – Workbook

This workbook has been prepared by Quasar Management Services Pty Limited, as a guide for use by not-for-profit NGOs in South Pacific village applications.



Quasar Management Services Pty Limited
ABN 21 003 954 210
Not-for-profit consulting structural and civil engineer
Subsidiary of Partner Housing Australasia (Building) Incorporated
69 Renwick Street, Redfern NSW 2016, Australia
Phone: +61 432 611 550
Email: RodJohnstonAUS@gmail.com

Water Supply Training – Introductory Level

Purpose

The purpose is to provide introductory level understanding of rural water supply to trainees, enabling them to construct village water supply systems, and to undertake more advanced training.

Workbook

- This workbook is for basic skills training for the construction of South Pacific village water supplies.
- The workbook employs photographs and diagrams where possible, with minimum use of text.
- More detailed training packages are available for higher level training. At the end of this workbook are extracts from *Solomon Islands Rural Water Supply, Sanitation and Hygiene - Design and Construction Standards, Version 2, November 2015*, which provide the basis for further training.
- The trainee is encouraged to make notes in the space provided.

Trainer

The Trainer must be an experienced builder, who has received instruction in the use of this material.

Training Resource Material

This material is sourced from Power Point presentations, that can be used as:

- Teaching presentations
- Printed work books, to be given to the trainees as a permanent reference
- Printed and laminated posters, that are placed on site
- As a source of details, which can be copied and placed onto project drawings.

Community Water Demand

5 litres/head/day – Minimum for rainwater harvesting projects when other water sources are available. WHO standard for minimum drinking quantity

10 litres/head/day – Absolute minimum for any water supply system. If rainwater is the only viable source, rainwater storage must be incorporated.

50 litres/head/day – **WHO minimum** for rural communities. Permissible when 100 litres/head/day cannot be supplied, with extra community expectation setting

100 litres/head/day – **Standard for rural communities**

Solomon Islands Environmental Health Division Ministry of Health and Medical Services (2019). "THE SOLOMON ISLANDS RURAL WATER SUPPLY, SANITATION & HYGIENE DESIGN AND CONSTRUCTION STANDARDS"

Category	Quantity	Description
Community	5 l/p/d	Minimum for rainwater harvesting projects when other water sources are available. Due to the very high (relative) costs for RWC projects, minimum water demand is set at 5 l/p/d in line with WHO standard for minimum drinking quantity
	20 l/p/d	Absolute minimum for any water supply system. If rainwater is the only viable source, this minimum amount must be met with rainwater storage. If a source cannot provide this minimum, it should be supplemented with rainwater storage
	50 l/p/d	WHO minimum for rural communities. Can still be used if 100l/p/d cannot be supplied by the source but will require extra community expectation setting
	100 l/p/d	The standard for rural communities
Inpatients	50 l/bed/day	When rainwater is the only water source available;
	100 l/bed/day	For combined rainwater and other water sources (where the other source is not able to provide 200 l/bed/day)
	200 l/bed/day	For large enough piped water supplies
Outpatients	5 l/outpatient	
Special: Maternity	100l/intervention	Dentist, laboratory etc.
Other	250l/d	
Special needs	50l/p/d	This is for PLWD with uncontrollable bowel movements (cerebral palsy) for whom medication is not effective. 50l/p/d regardless of the water source

Design Population

The design population of a village (P_N) is the projected population in the last year of the design life. Consideration should be given to whether there are **constraints on future population growth?**

“Simple” increase Population less than (or equal) 2,000 $P_N = P_O \left(1 + \frac{rN}{100}\right)$

“Compounding” increase Population greater than 2,000 $P_N = P_O \left(1 + \frac{r}{100}\right)^N$

P_N = design population

P_O = initial population

r = percentage projected growth rate

N = design life (years)

- One tapstand for maximum of 5 households, unless in conflict with:
- Access to water no more than 30 minutes round-trip including queuing (this may mean that 3 households located relatively far away would get their own tapstand);
- One well (with or without hand pump) for maximum of 20 households, unless in conflict with point above (30 minutes' total collection time);

Plumbing Symbols

The following symbols are used in this training package to indicate various fittings.

Other fittings are defined in International Standards.

<https://www.bing.com/images/search?q=plumbing+symbols+australia&id=2A908889A796F73881A8CE96A85D81C5DF491B75&FORM=IQFRBA>



Gate valve. Other types of valves such as ball valves may be appropriate.

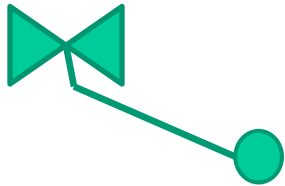

Float valve, set to close when the water level reaches a set level.



Check valve (non-return valve)



Elbow



Tee

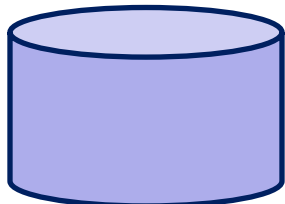

Tank

Water Supply Arrangements

The main components of a rural water gravity supply system are :

- A dam or a spring box, to collect the water



- A pipe from the dam (gravity main) is large enough to for the required flow

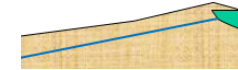

- A break-pressure tank, if the pipeline pressures exceed safe limits

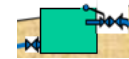

- Standpipes to deliver the water



- Roof gutters and domestic storage tanks



- If necessary, holding tanks with control valve to distribute water equitably.

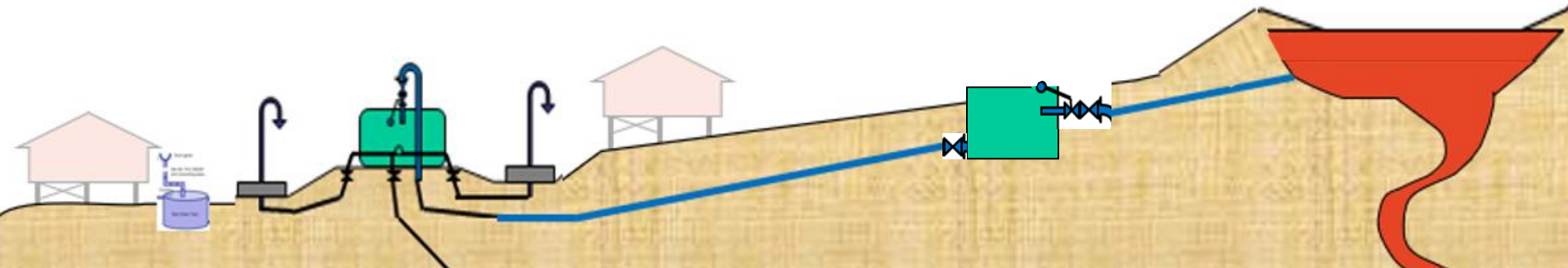
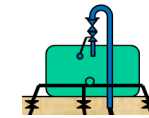

Water Supply Location

Water sources should be above houses and above latrines.

Latrines and/or
houses above
water source

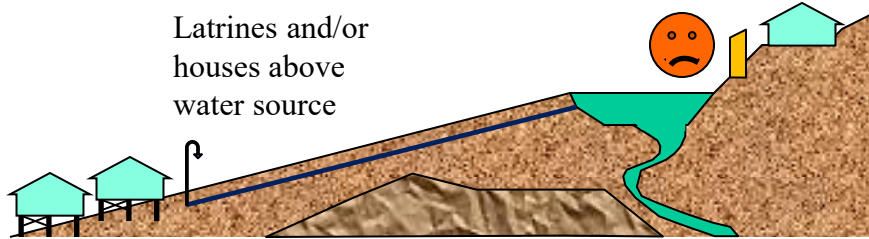

Latrines and houses
below water source

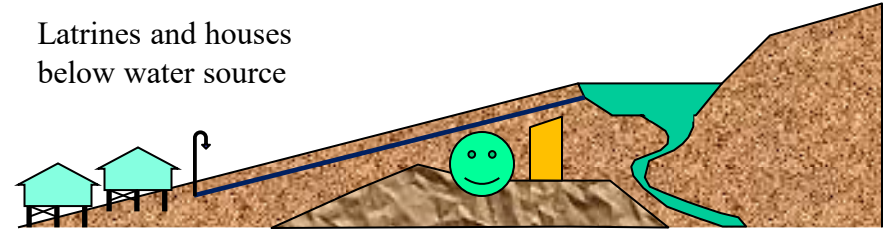

The flow of water to the standpipes will be equitable provided:

- The dam inlet is significantly higher than the standpipes, and
- The pipe from the dam (rising main) is large enough; and
- The standpipes are at similar levels and turned off when not in use.

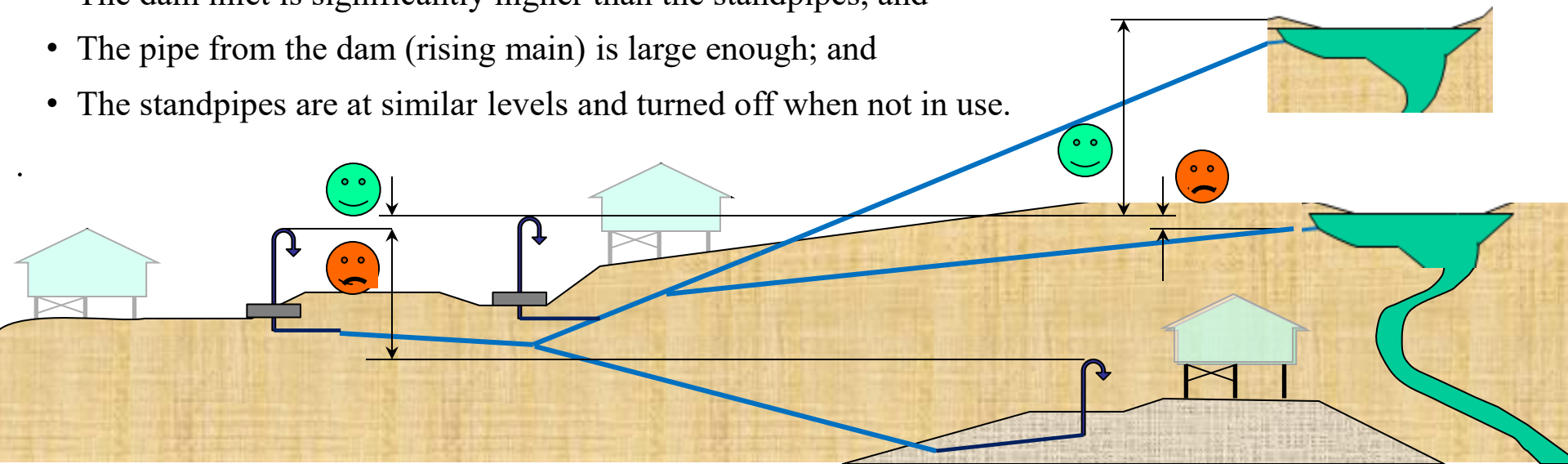

Water Supply Arrangements

If one or more of the standpipes are located below the others, they could drain the system. To avoid this problem, consider installing a holding tank with throttling outlet valves set to limit the flows to all standpipes. These valves must be managed by a person with the authority to control the flow to each standpipe.

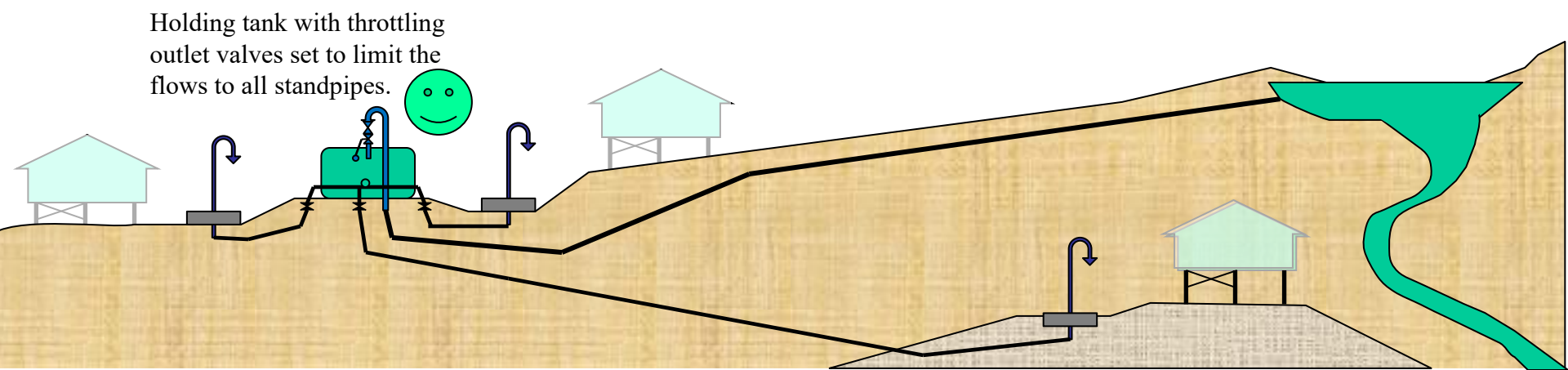
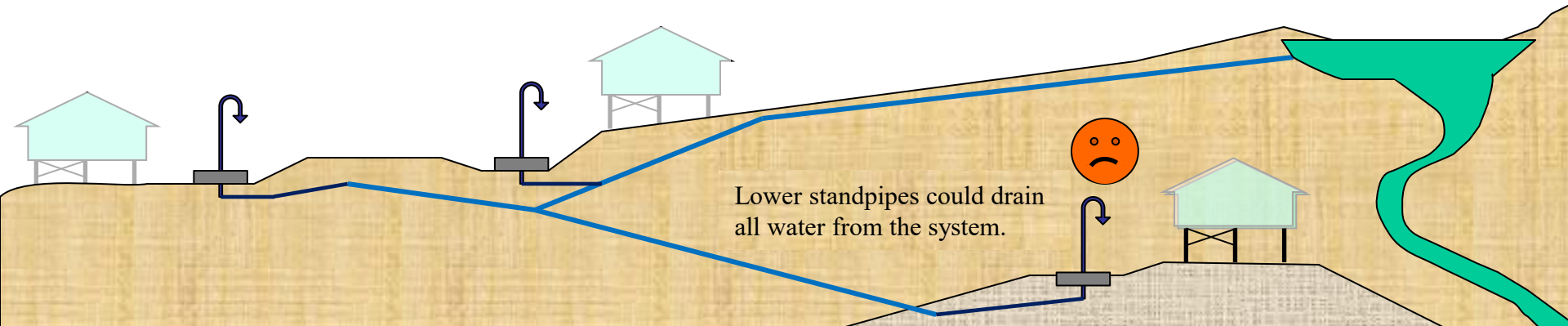

Dams

Dams are walls constructed in a creek bed to collect creek water.

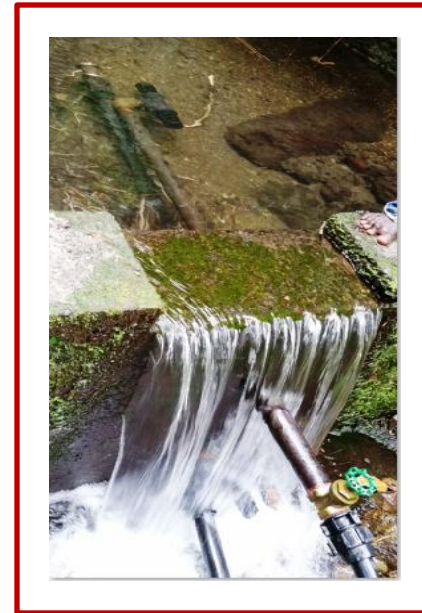

Dams

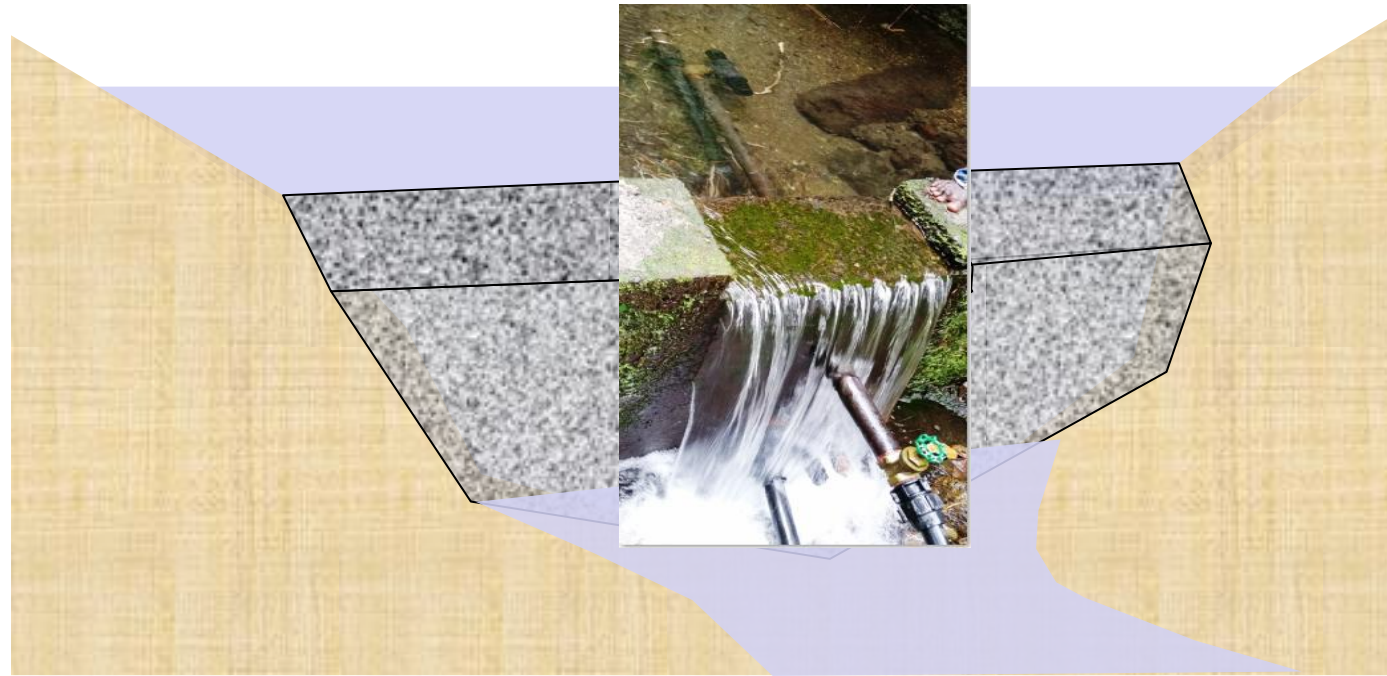

Dams – Keyed into Abutting Rock Outcrops

Water pressure behind and under dams will push them over unless they are firmly wedged between rock outcrops (or a rock-bolted to rock shelf below.)

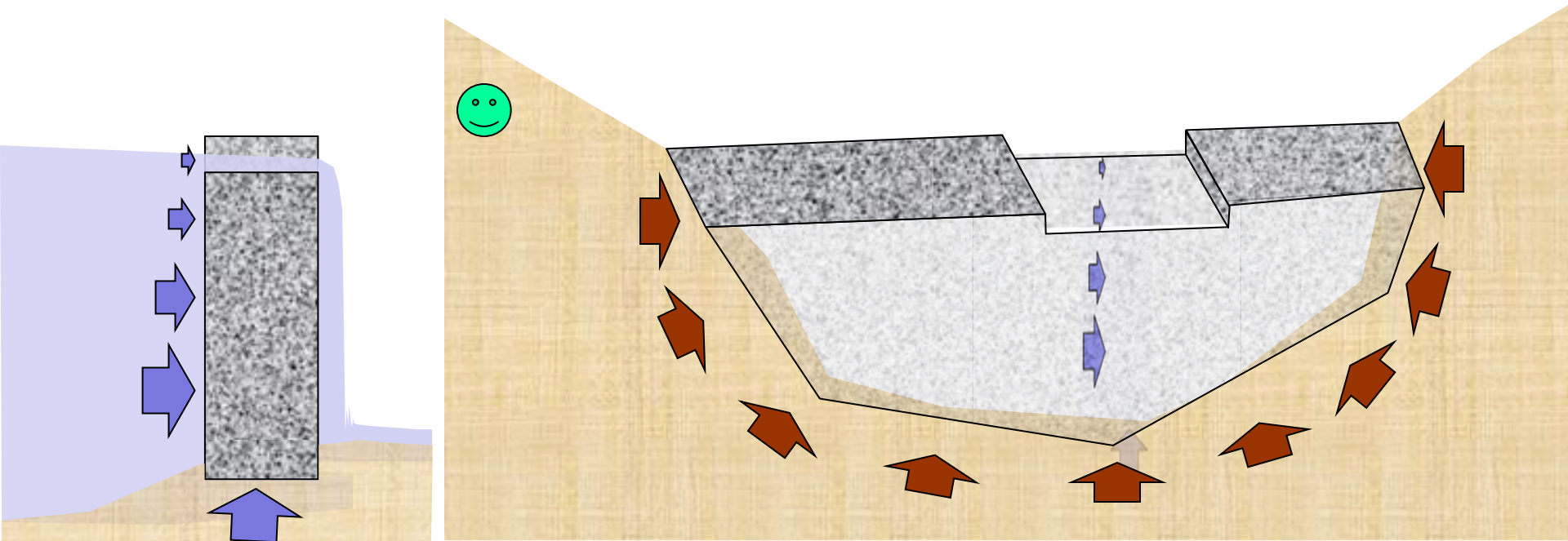

Dams – Reinforced Concrete Walls

To resist water pressure, all dams should be steel reinforced concrete, with horizontal and vertical reinforcement designed by an engineer.



Vertical reinforcement for future extension

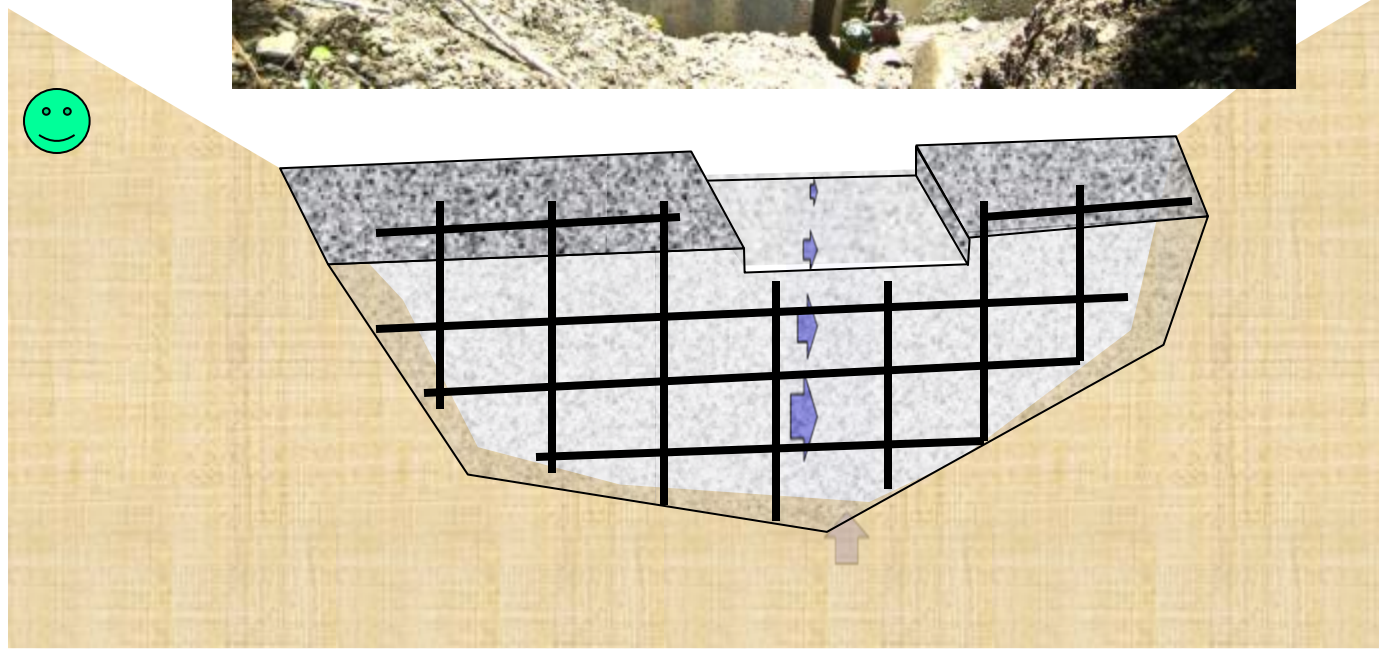
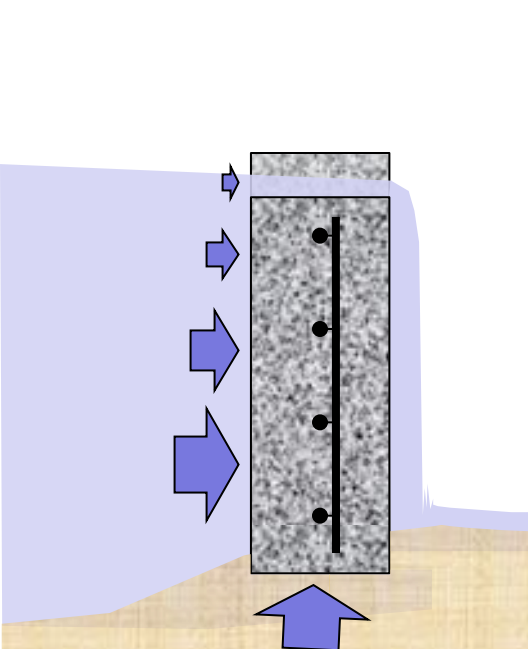

Dams – Water Intake and Flushing Arrangement

Suspended solids will eventually drop to the bottom of the dam, which should be flushed regularly through a flushing pipe and valve. Relatively clear water should be drawn from near the top of the dam, through a large leaf strainer, pipe and valve.

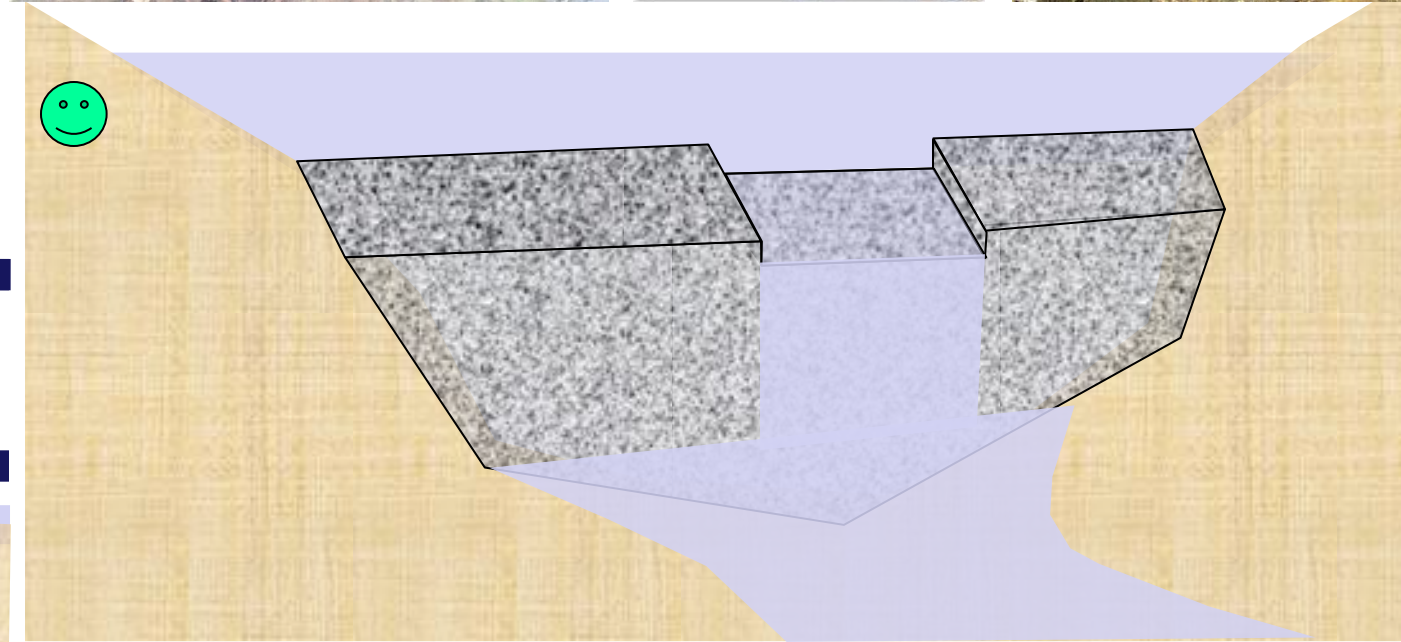
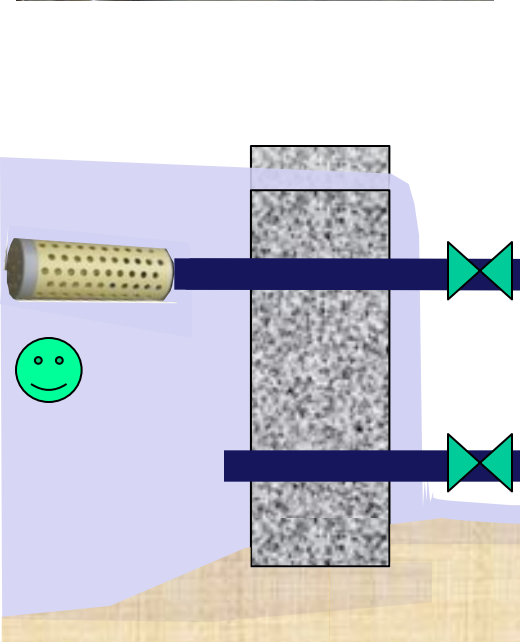
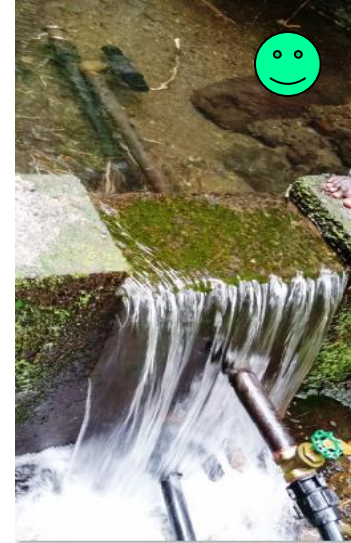

Spring Box

Spring boxes are concrete boxes constructed in a creek bed to collect water, allowing the suspended solids to drop to the bottom and relatively clear water to be drawn from the top.



Spring Box Concrete



Notes:

Height may be varied to suit the site conditions, including the fall in the creek bed and resulting heights of inlet and outlet. This design and the quantities tabulated are for a maximum height of 1.2 metres (overall external dimensions).

Concrete shall be poured in each wall such that the differential height of concrete is no more than 300 mm.



20 MPa Concrete (by volume) 1 : 2 : 4		1 Spring Box
Volume of concrete	m ³	1.00
Wastage included	%	11%
GP or GB cement	40 kg bags	8
Clean sharp sand	m ³	0.5
20 mm rock aggregate	m ³	1.0
Steel reinforcement	N10 S Bend on site	96 @ 1100 64 @ 600
Timber formwork	mm x mm No @ m	100 X 50 HW 44 @ 1.5 (re-use)
Plywood formwork	No @ m x m	6 plywood 5 @ 1.2 x 1.2 (re-use)

For 1 cubic metre (1 m³)
of 20 MPa concrete

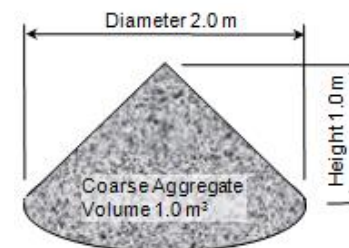
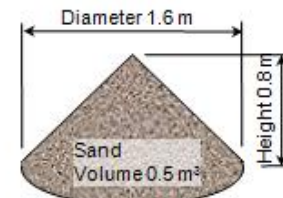

Spring Box Plan and Formwork

Notes:

Height may be varied to suit the site conditions, including the fall in the creek bed and resulting heights of inlet and outlet. This design and the quantities tabulated are for a maximum height of 1.2 metres (overall external dimensions).

Concrete shall be poured in each wall such that the differential height of concrete is no more than 300 mm.

Detail "B" is the same as Detail "A" except use one bearer per wall.

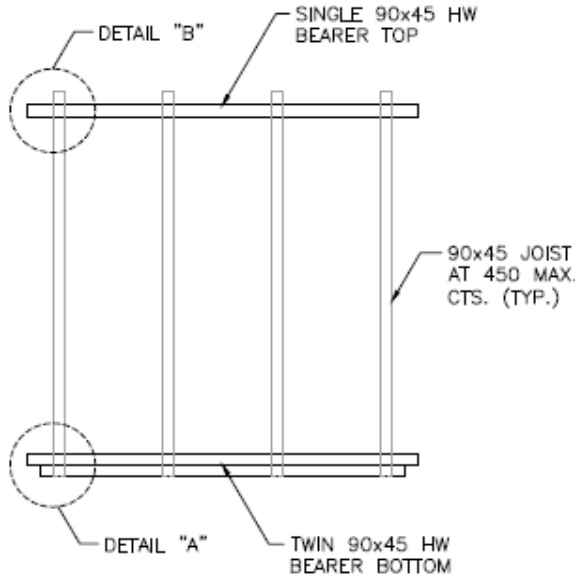

FORMWORK - WALL ELEVATION

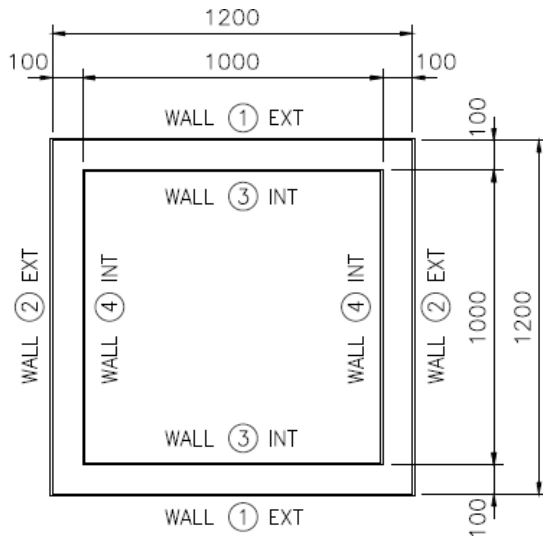

FORMWORK - WALL PLAN

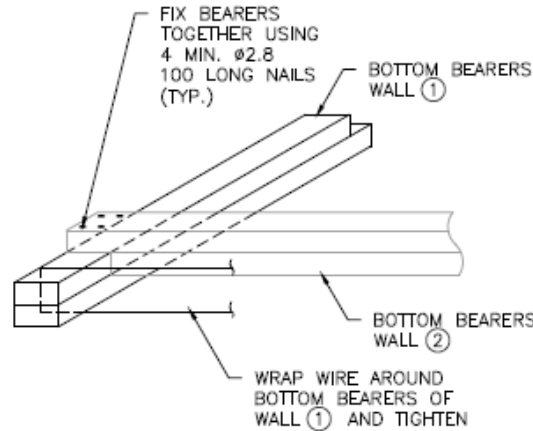

DETAIL A

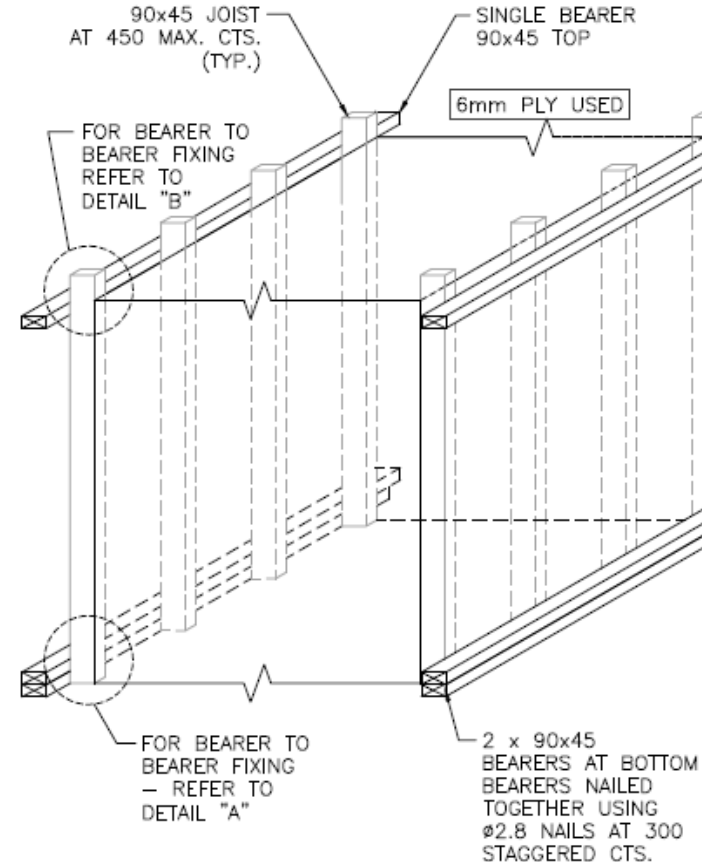

EXTERIOR FORMWORK DETAILS

Spring Box Reinforcement

NOTES:

1. WHEN POURING BASE, TIE HORIZONTAL REO TO THE TOP OF THE VERTICAL STARTER BARS TO PREVENT STARTER BARS FROM MOVING.
2. PROVIDE 40mm COVER TO ALL REINFORCEMENT.

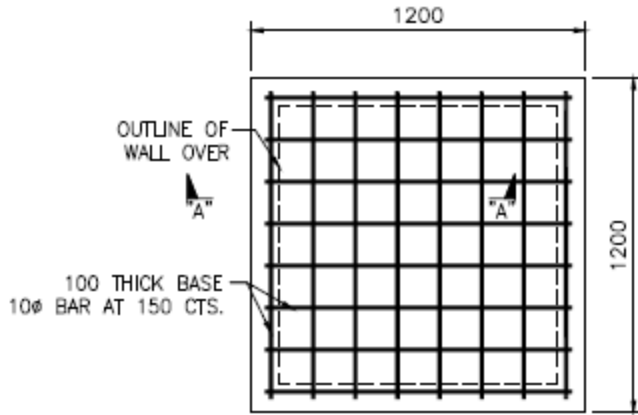

BASE REINFORCEMENT PLAN

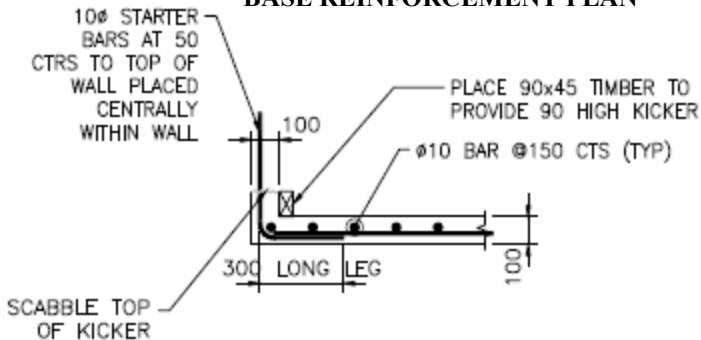

SECTION A

NOTES:

1. WALLS 100mm IN THICKNESS, PROVIDE #10 BAR AT 150 CTS. PLACED CENTRALLY BOTH WAYS (WALLS 1000mm HIGH).

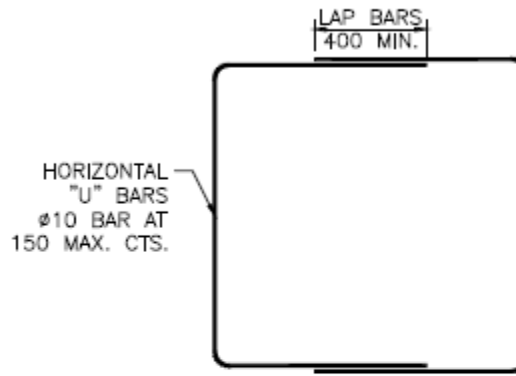

BAR LAPPING PLAN - OPTION 1

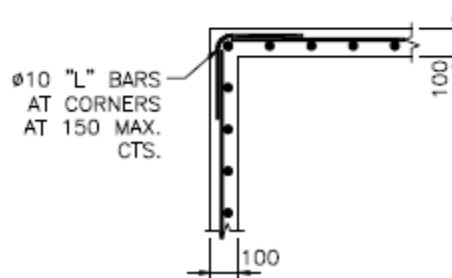

BAR LAPPING PLAN - OPTION 2

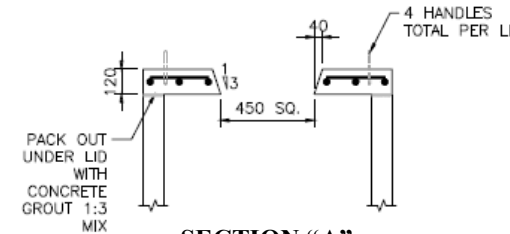
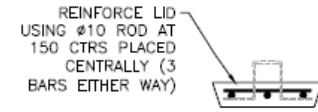

SECTION "A"

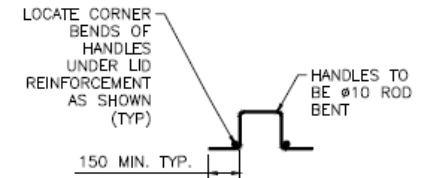

HANDLE DETAIL

NOTES:

1. LID 120mm THICK

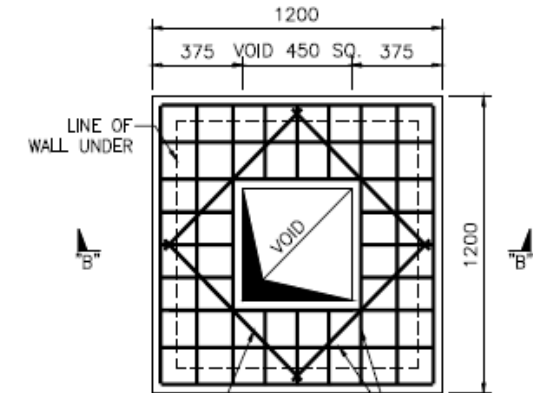

10Ø TRIMMER BARS (800mm LONG) AT EACH CORNER PLACED CENTRALLY

PROVIDE 10Ø BARS AT 150 MAX. CTS. PROVIDE 3 MIN. BARS FOR EACH SIDE OF VOID PLACED CENTRALLY

LID REINFORCEMENT

Pipes and Fittings



Pipes and Fittings – Importance of Protecting Pipes

Flash floods may damage pipes.

- Bury pipes deeply;

OR

- Suspend pipes from stainless steel wires pulled tightly between strong trees, tied back into soil anchors. For crossings under 10 metres long, use two length of galvanised pipe to protect the HDPE water pipe.

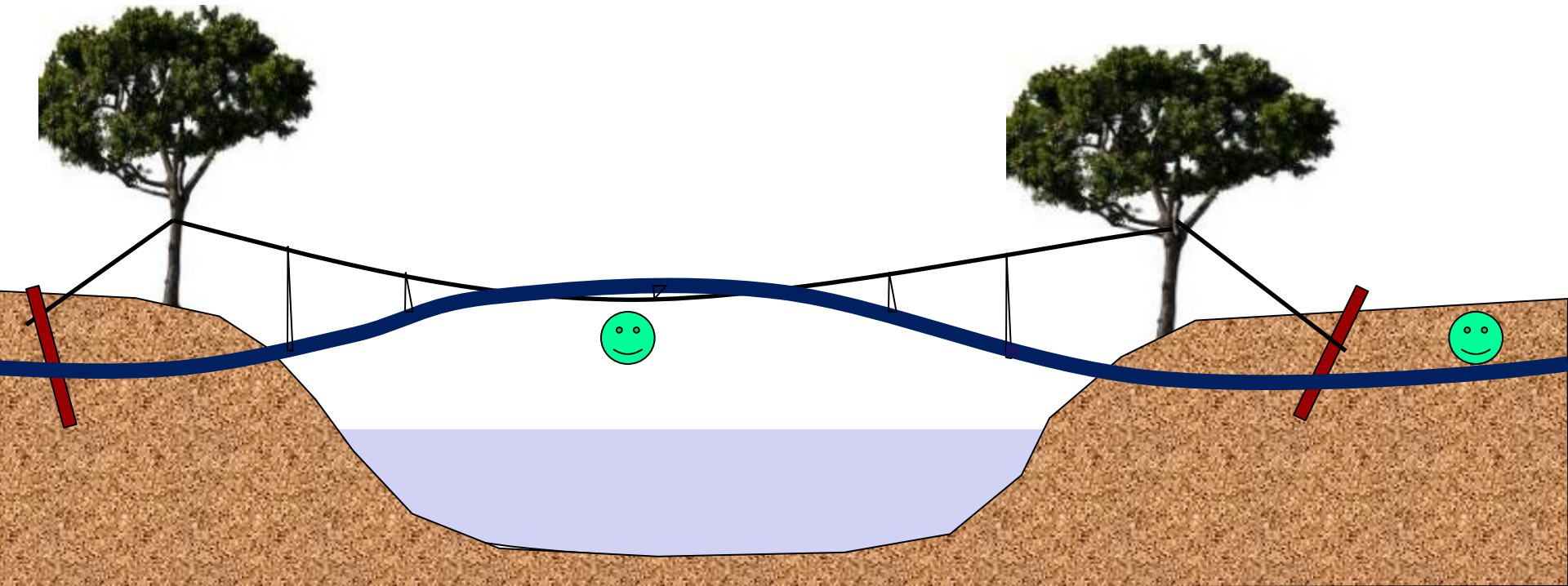

Standpipes

Standpipes provide water for communal use, usually close to the houses that they service. The main components are:

1. Low maintenance reinforced concrete slab, with 40 mm deep Vee draining to a 20 mm coarse gravel soak-away.
2. Either a concrete filled **DN150** PVC pipe, containing the riser or a timber privacy screen frame may be used to provide support to the plumbing pipework.
3. Timber privacy screen, when specified.
4. **DN20** plumbing, consisting two taps, one controlling an overhead shower and the other delivering water at waist height for filling buckets and washing.



Solomon Islands Rural Water Supply and Sanitation (Clause 5.3.4) recommends the use of DN20 (3/4") plumbing for village standpipes.

The following details have been developed by Quasar, from the RWSS specification modified to suit the material and construction skills available.

In the past, galvanised iron pipework has been specified. HDPE pipes and fittings may be substituted, if properly supported.

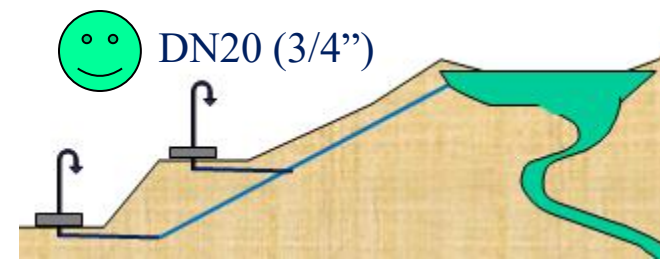

Standpipe Concrete Pads

		1	4
20 MPa Concrete (by volume) 1 : 2 : 4		Stand Pipe Base	Stand Pipe Bases
Volume of concrete	m ³	0.26	1.00
Wastage included	%	10%	
GP or GB cement	40 kg bags	2	8
Clean sharp sand	m ³	0.1	0.5
20 mm rock aggregate	m ³	0.3	1.0
SL 62 steel mesh	No-mesh m x m	1 – SL72 1.15 x 1.15	4 – SL72 1.15 x 1.15
Timber formwork	m	100 X 50 HW x 4.8 (re-use)	100 X 50 HW x 4.8 (re-use)

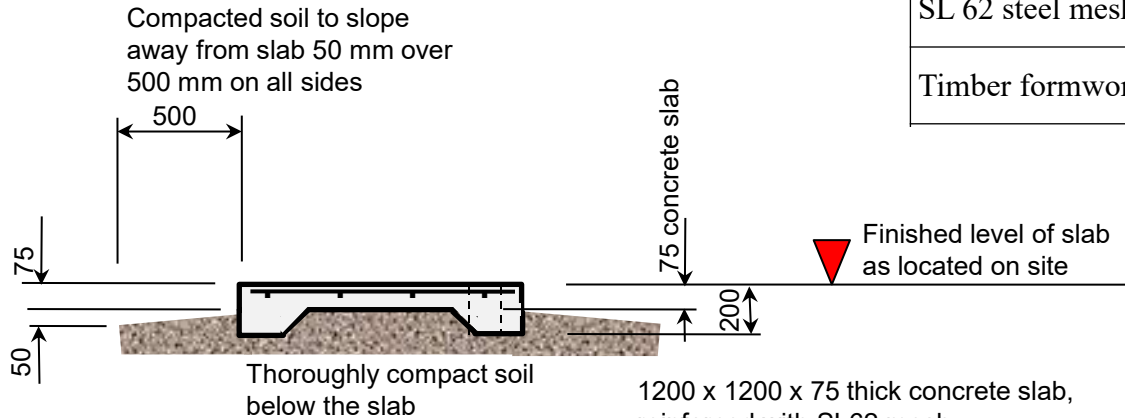

1200 x 1200 x 75 thick concrete slab, reinforced with SL62 mesh with 200 x 200 edge thickening

For the "Low Maintenance Slab", the top surface is flat, except that there is a 10 mm fall to corner 4. This is achieved by keeping corners 1, 2 and 3 at the same level, and dropping corner 4 by 10 mm. The wet concrete is screeded from the diagonal 2-4 towards corners 1 and 3. The water will drain slowly towards corner 4 and a soak-away can be positioned extending from corner 4.

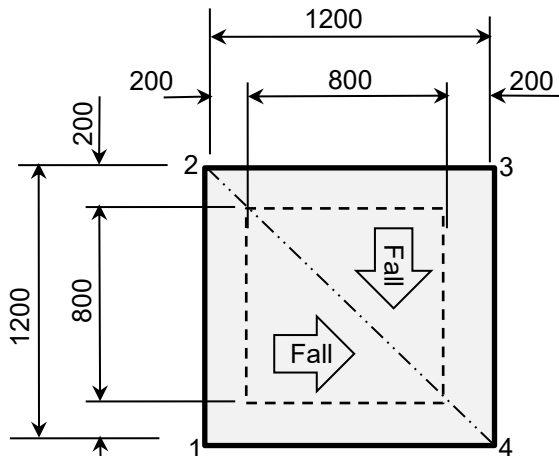

Low Maintenance Slab

For 1 cubic metre (1 m³) of 20 MPa concrete

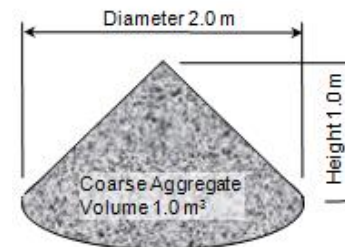
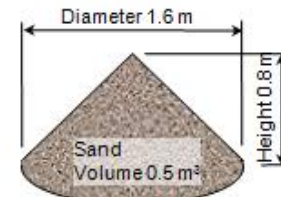

Conventional Standpipe Plumbing

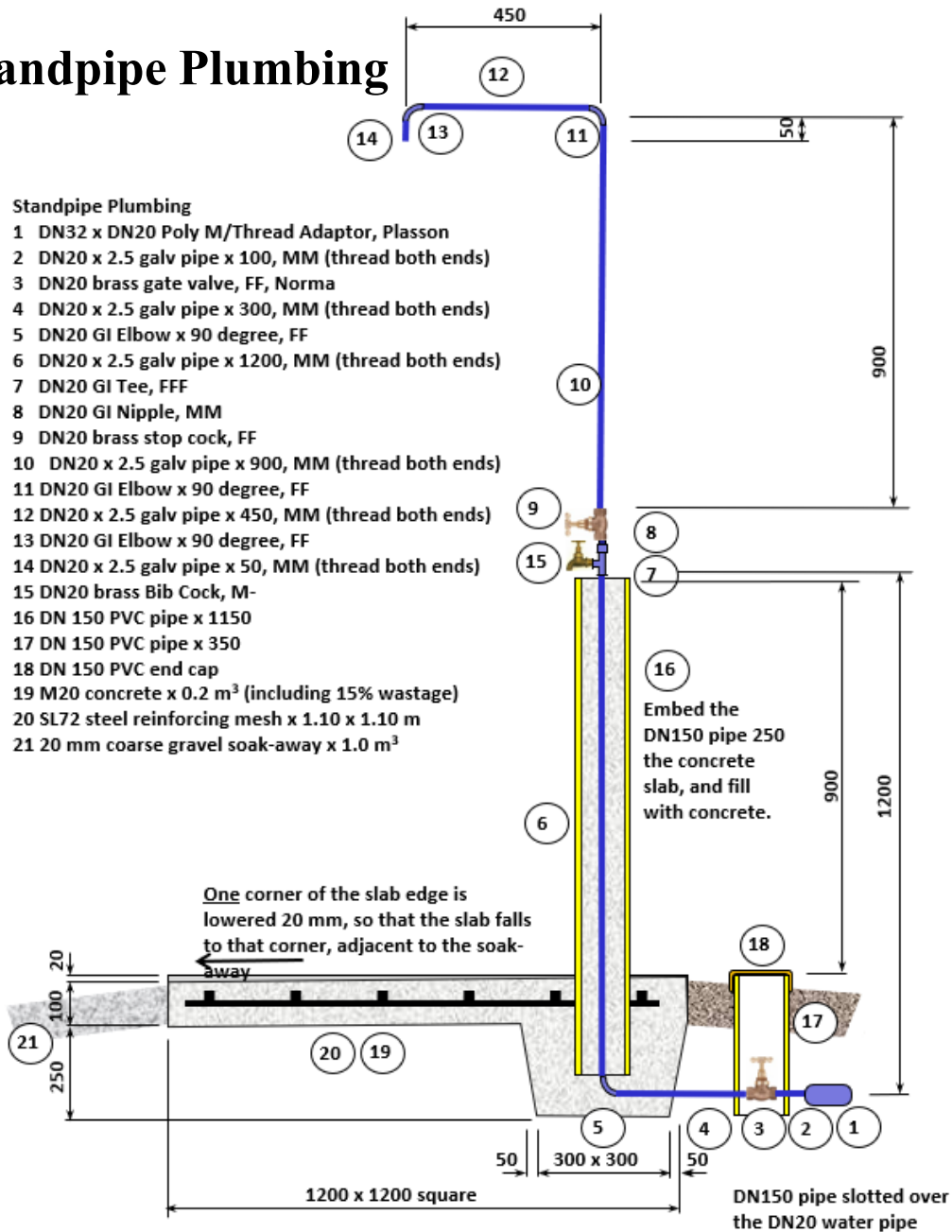

Section through standpipe

Standpipe Upgrade Kit

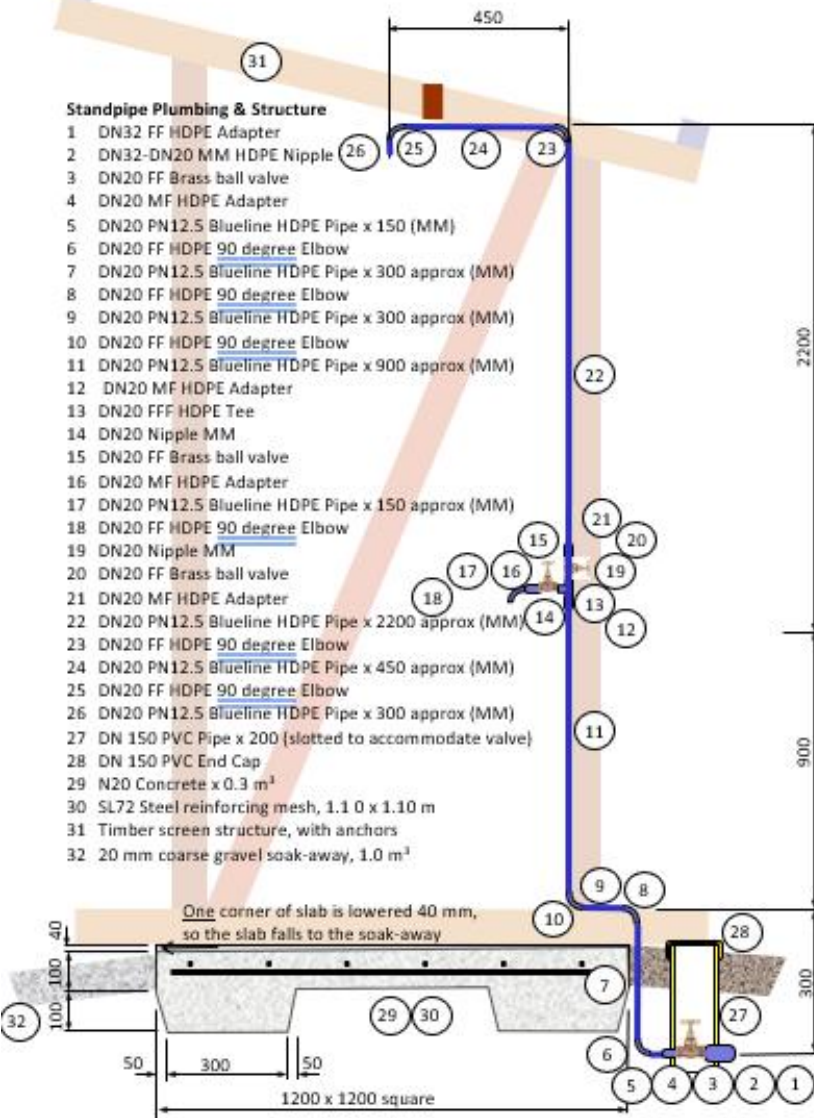

Section through standpipe

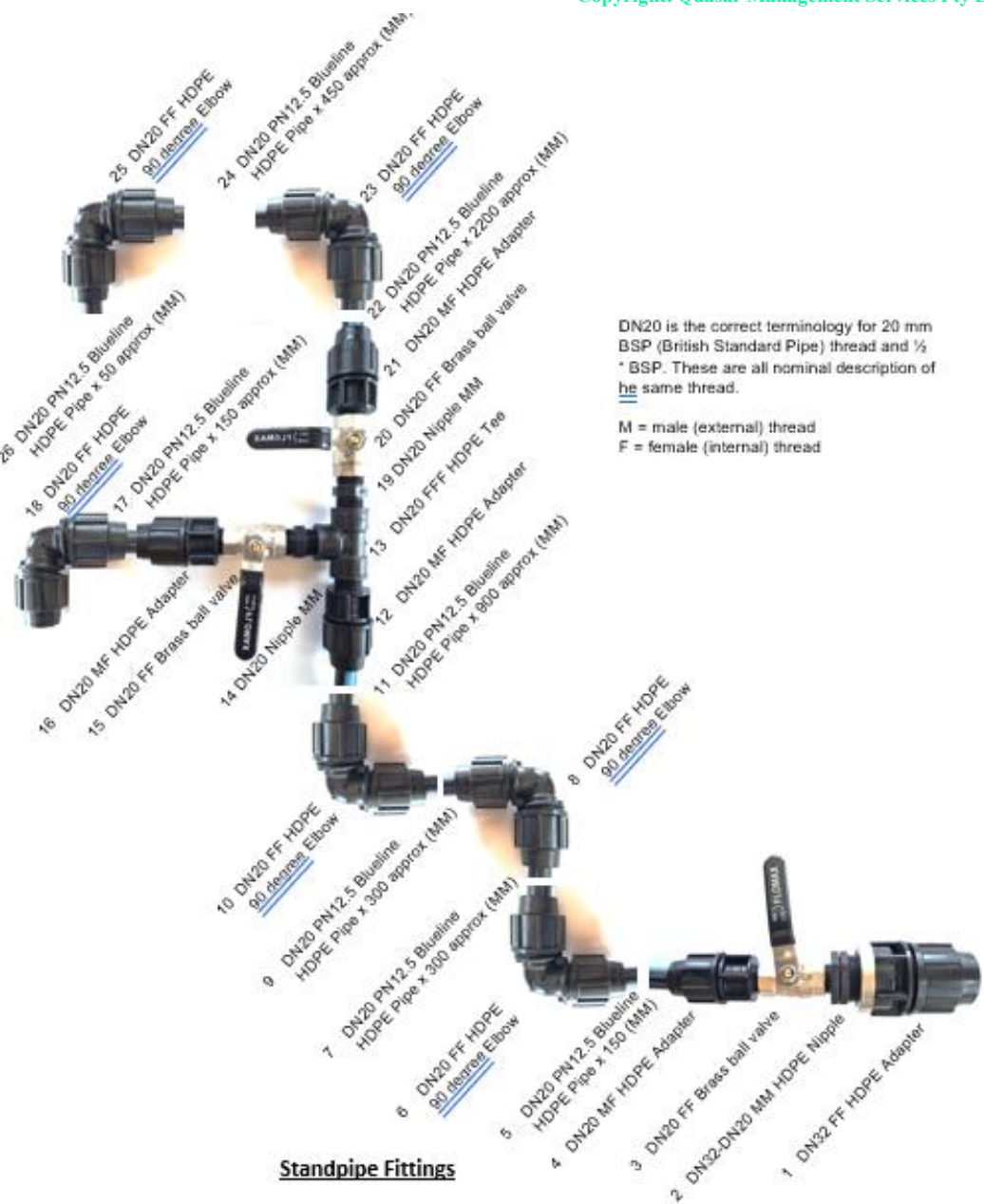

DN20 is the correct terminology for 20 mm BSP (British Standard Pipe) thread and 1/2" BSP. These are all nominal descriptions of the same thread.

M = male (external) thread
F = female (internal) thread

Privacy Screens

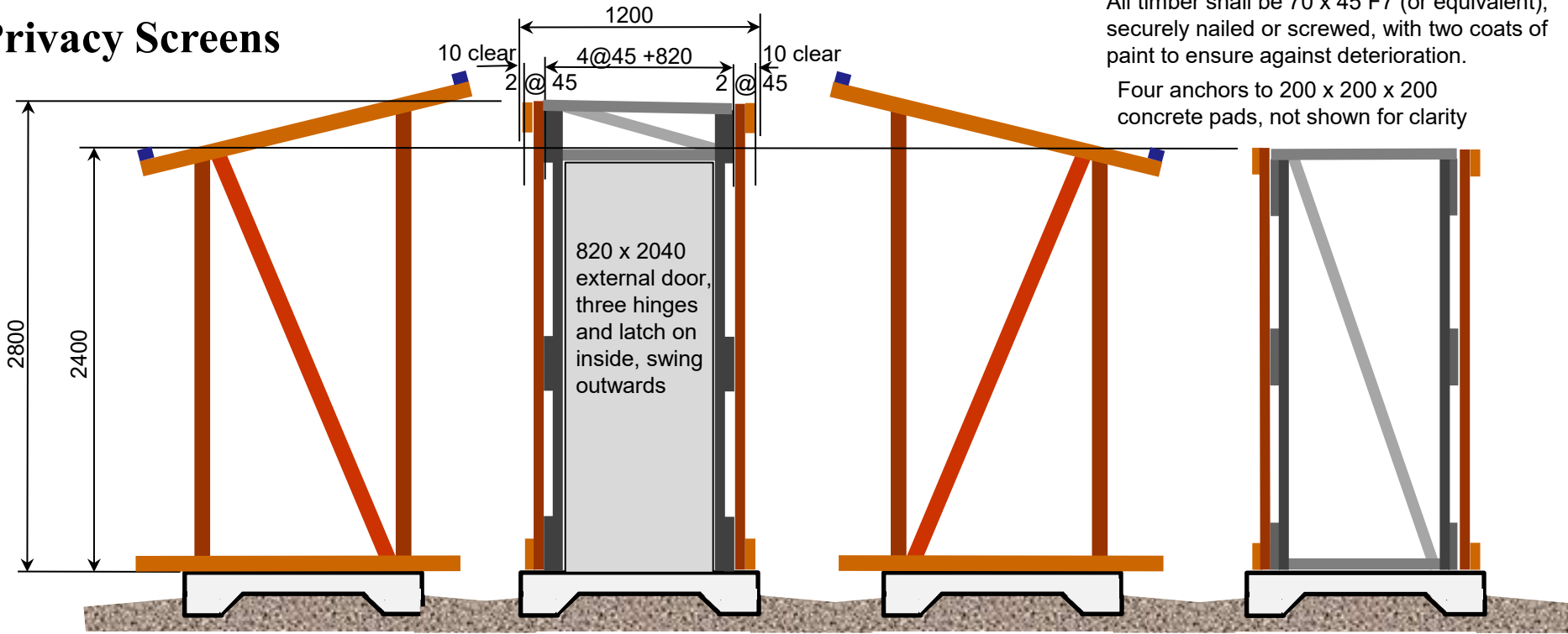

All timber shall be 70 x 45 F7 (or equivalent), securely nailed or screwed, with two coats of paint to ensure against deterioration.

Four anchors to 200 x 200 x 200 concrete pads, not shown for clarity

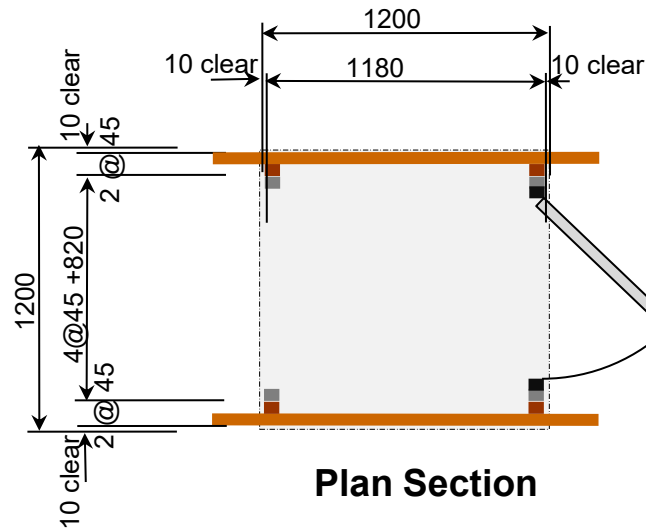
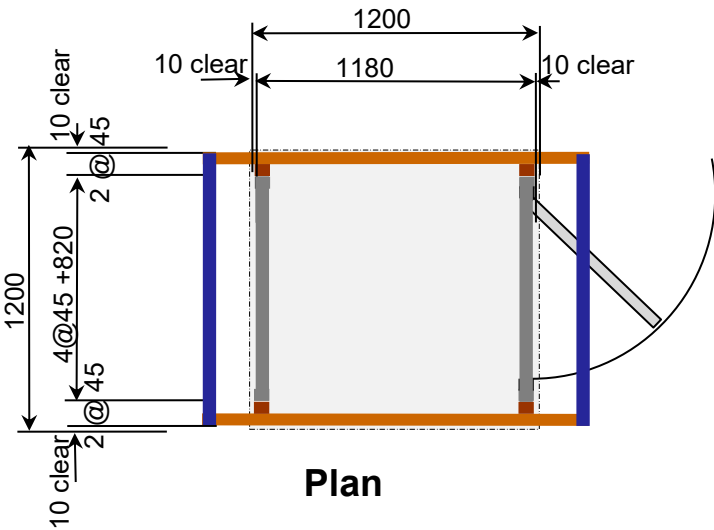

Privacy screens are an option for village standpipes. They may be retrofitted after the slab and standpipe are constructed. They consist of four prefabricated side frames (the front one with a door fitted). They are erected, and fixed together and normally would not have a roof. An optional roof may be fitted by fixing the two (blue) purlins, and fixing roof sheeting. The wall cladding is not shown or specified in this drawing, and may be selected from suitable local materials. The whole structure must be securely anchored.

Standpipe Concrete Pads

After the standpipe plumbing is installed, a reinforced concrete pad shall be constructed to provide a non-slip surface where people can stand to wash or obtain water.

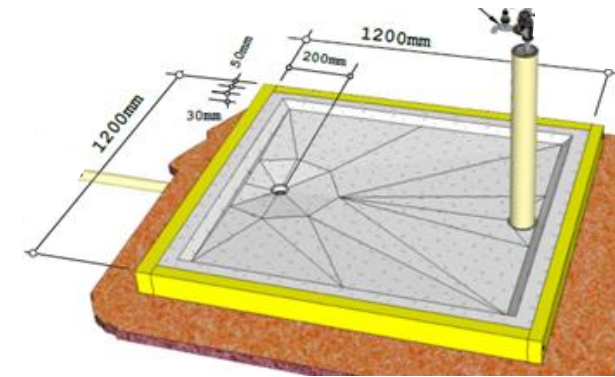

Dished Slab

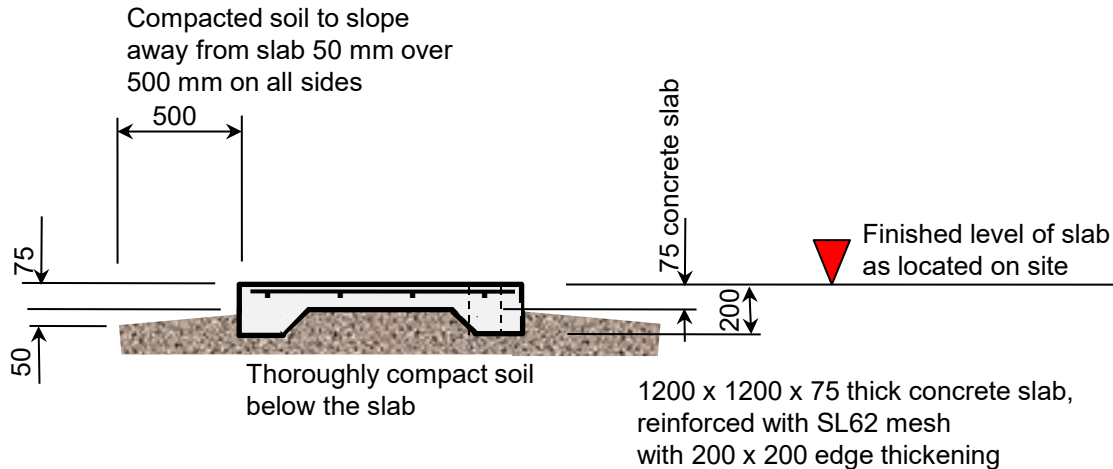

Option 1 – Dished Slab

If the surrounding ground is relatively flat with poor drainage, the concrete pad should be dished with a drain hole and drainage pipe sloping uniformly downwards to remove the waste water a convenient distance. This is more difficult to construct and may become slippery if the drain is not kept clear.

Option 2 – Low Maintenance Slab

If the surrounding ground is sloping and well drained, the concrete pad may be constructed flat, with a very slight slope to one corner. This is easier to construct and easier to maintain.

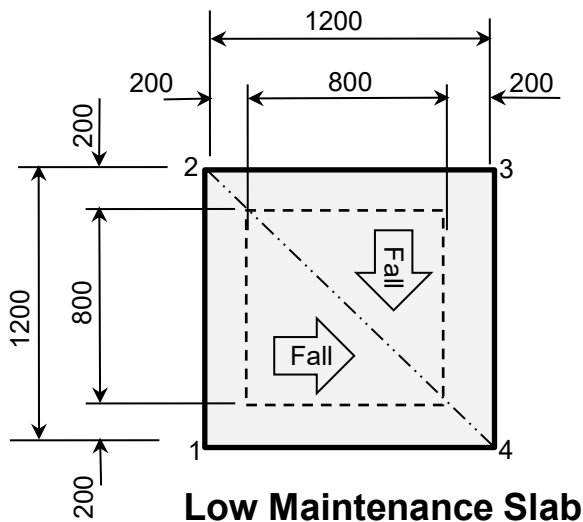

For the “Dished Slab”, the top surface of slab should be rebated to channel water towards a drain at the low point.

For the “Low Maintenance Slab”, the top surface is flat, except that there is a 10 mm fall to corner 4.

Typical Small Village Water Supply

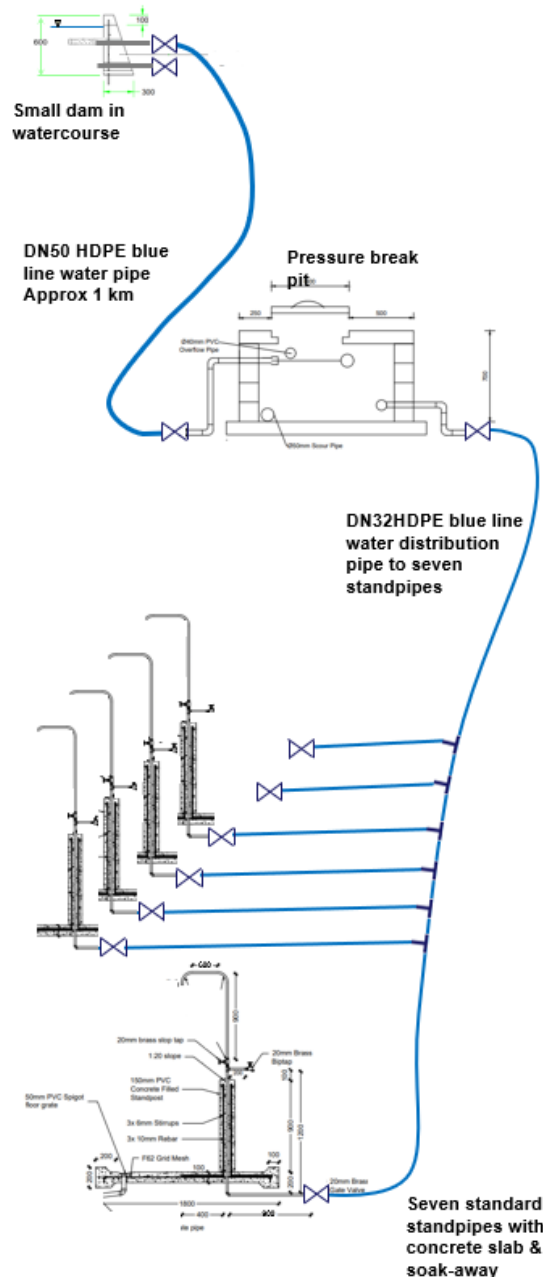

Plumbing Pipes and Fittings

Pipes and fittings are listed in order, progressing from the dam to the standpipes.

Dam

Dam Outlet

DN50 PVC end cap
 DN50 x 300 mm PVC pressure pipe with drilled holes
 DN50 female BSP faucet socket PVC pressure
 DN50 GI pipe x 1.0 m - with both ends threaded
 DN50 gate valve brass, F GVB50, Norma
 DN50 galvanised hex nipple

Dam Scour

DN50 galvanised pipe x 1.0 m, with both ends threaded
 DN50 gate valve brass, 2-inch F GVB50, Norma

Water Main – 1.0 km approximate length

DN50 blue line HDPE pipe, 150 m/coil PN12.5 A S/NZ 4130 (7 Req)
 DN50 poly coupling, Plasson (8 Req)

Break-Pressure Tank

Break-Pressure Tank Inlet

DN50 Poly metric/thread adaptor, Plasson
 DN50 galvanised hex nipple
 DN50 gate valve brass, FF GVB50, Norma
 DN50 x 3 mm galvanised pipe x 100 mm, thread both ends
 DN50 x 90-degree galvanised elbow
 DN50 x 3 mm galvanised pipe x 500 mm, thread both ends
 DN50 x 90-degree galvanised elbow
 DN50 x 3 mm galvanised pipe x 500 mm, thread both ends
 DN50 ball float valve, tank floator

Break-Pressure Tank Outlet

DN50 PVC end cap
 DN50 x 300 mm PVC pressure pipe with drilled holes
 DN50 female BSP faucet socket PVC pressure
 DN50 x 3 mm galvanised pipe x 500 mm, thread both ends
 DN50 x 90-degree galvanised elbow
 DN50 x 3 mm galvanised pipe x 100 mm, thread both ends
 DN50 x 90-degree galvanised elbow
 DN50 x 3 mm galvanised pipe x 100 mm, thread both ends
 DN50 gate valve brass, FF GVB50, Norma
 DN50 galvanised hex nipple
 DN50 Poly metric/thread adaptor, Plasson

Break-Pressure Tank Scour

DN50 galvanised pipe x 1.0 m, with both ends threaded
 DN50 gate valve brass, FF GVB50, Norma

Break-Pressure Tank Overflow

DN50 x 88-degree DWV PVC plain bend
 DN50 PVC Pipe (DWV) x 2.0 m

Distribution Pipework – 1.4 km approximate length

DN50 poly coupling, Plasson
 DN50 x DN32, poly reducing set, Plasson
 DN32 poly coupling, Plasson
 DN32 x 90-degree poly tee, Plasson
 DN32 blue line HDPE pipe x 200 m/coil, PN12.5, A S/NZ 4130

Standpipes – 7 Required

DN32 x DN20 Poly M/Thread Adaptor, Plasson
 DN20 brass gate valve, FF, Norma
 DN20 x 2.5 mm galvanised pipe x 900 mm, thread both ends
 DN20 galvanised elbow x 90-degree FF
 DN20 x 2.5 mm galvanised pipe x 1200 mm, MM (thread both ends)
 DN20 galvanised socket FF
 DN20 galvanised tee MMM
 DN20 brass stop cock, FF
 DN20 x 2.5 mm galvanised pipe x 900 mm, MM (thread both ends)
 DN20 galvanised elbow x 90-degree FF
 DN20x 2.8 mm galvanised pipe x 600 mm, MM (thread both ends)
 DN20 galvanised elbow x 90-degree FF
 DN20 x 2.5 mm galvanised pipe x 200 mm, MM (thread both ends)
 DN20 brass hose cock / R, TH FF

Standpipe Drains – 7 Required

DN50 drop in grate poly round white
 DN50 x 88-degree DWV PVC plain bend
 DN50 DWV PVC pipe x 2.0 m (cut from 3.8 m length)

Roof Gutters, Rainwater Downpipes and Tanks



Roof Gutters, Rainwater Downpipes and 3,000 litre Tanks

These materials are required to connect one cottage to one 3,000 litre storage tank.

It is important that all fittings are compatible and should all be sourced from one supplier only. Do not to mix and match products/fittings from more than one source.

Materials for One Gutter, Downpipe, 3000 litre Tank

5 metres PVC “Marley” Rainwater Guttering

1 x PVC “Marley” Guttering Connector/Junction

8 x PVC “Marley” Rainwater Guttering Support Brackets

2 x PVC “Marley” Guttering Ends (1 left-hand, 1 right-hand)

1 x PVC “Marley” Guttering 80mm Spout Junction

4 metres 80mm PVC “Marley” Pipe

2 x 80mm 45° PVC “Marley” Bends

2 x Metal 80mm downpipe support Brackets

1 x DN15 Brass Bib Cock (male)

1 x DN20(male) x DN15(female) Galv Reducing Socket

1 x 250ml PVC Cement Glue (sufficient for 6 cottages)

1 kg Flathead Galv 50mm Clout Nails (this is sufficient for 6 cottages)

1 x 30m heavy duty Teflon Tape (for sealing threads on taps & socket reducers) (this is sufficient for 12 cottages)

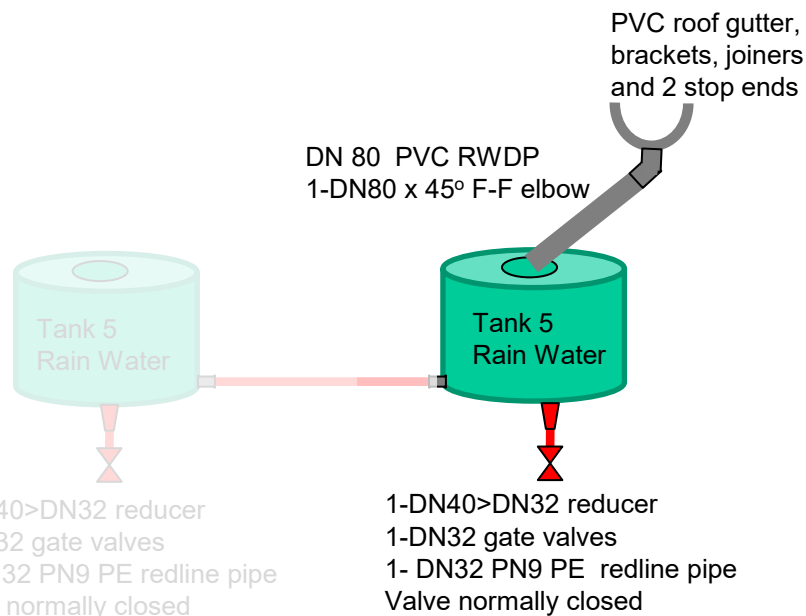

Concrete Tank Stand for One 3,000 litre Tank

		1	2
20 MPa Concrete (by volume) 1 : 2 : 4		Single Tank Pad	Single Tank Pads
Volume of concrete	m ³	0.58	1.00
Wastage included	%	10%	
GP or GB cement	40 kg bags	5	8
Clean sharp sand	m ³	0.3	0.5
20 mm rock aggregate	m ³	0.6	1.0
SL 62 steel mesh	No-mesh m x m	1 - SL62 1.95 x 1.95	2 - SL62 1.95 x 1.95
Timber formwork	m	100 X 50 HW x 8.0 (re-use)	100 X 50 HW x 8.0 (re-use)

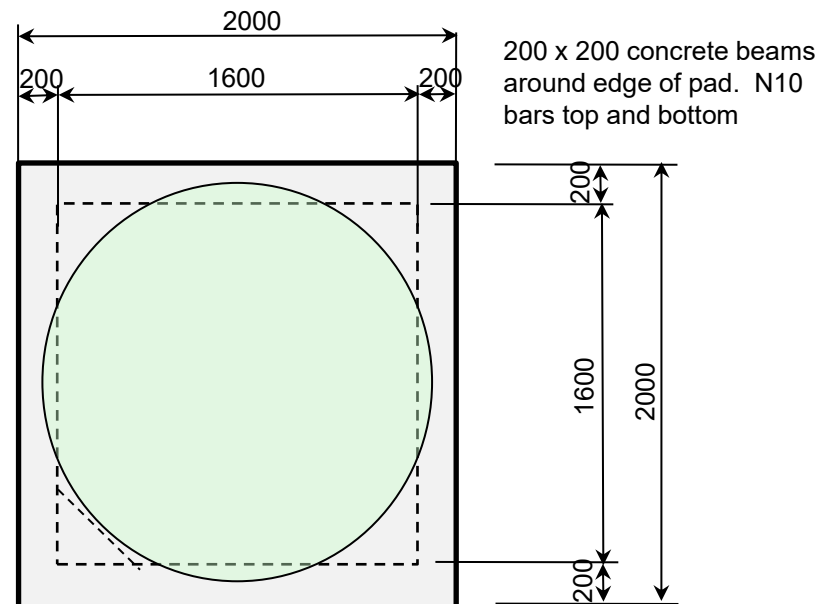
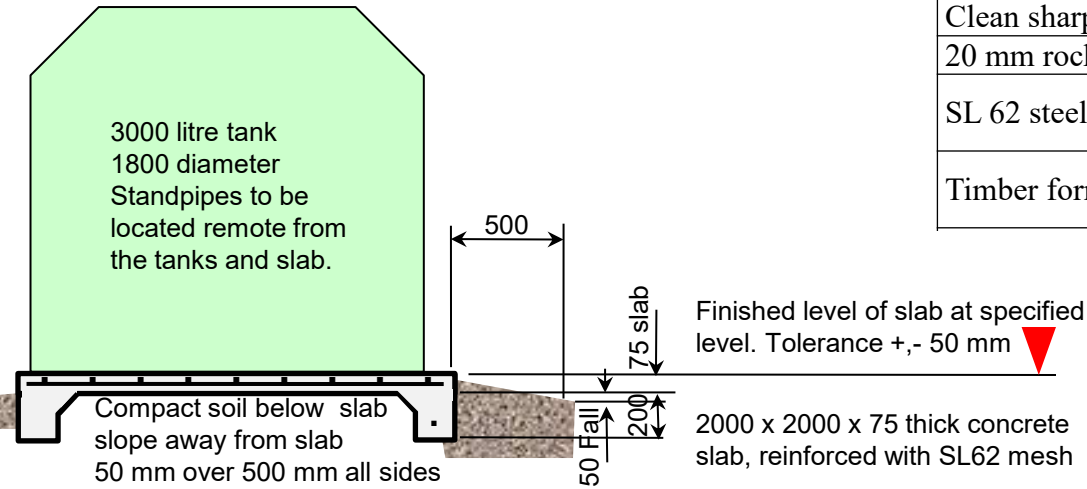

For 1 cubic metre (1 m³) of 20 MPa concrete

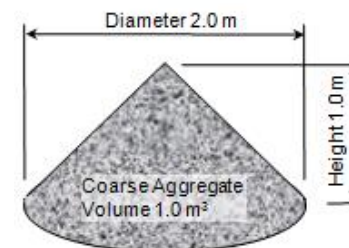
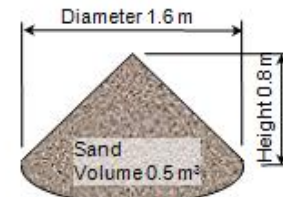

Concrete Tank Stand for One 3,000 litre Tank

20 MPa Concrete (by volume) 1 : 2 : 4		1 Double Tank Pad	1 Double Tank Pads
Volume of concrete	m ³	1.08	1.00
Wastage included	%	10%	
GP or GB cement	40 kg bags	9	8
Clean sharp sand	m ³	0.5	0.5
20 mm rock aggregate	m ³	1.1	1.0
SL 62 steel mesh	No-mesh m x m	1 - SL62 3.75 x 1.95	1 - SL62 3.75 x 1.95
Timber formwork	m	100 X 50 HW x 11.6 (re-use)	100 X 50 HW x 11.6 (re-use)

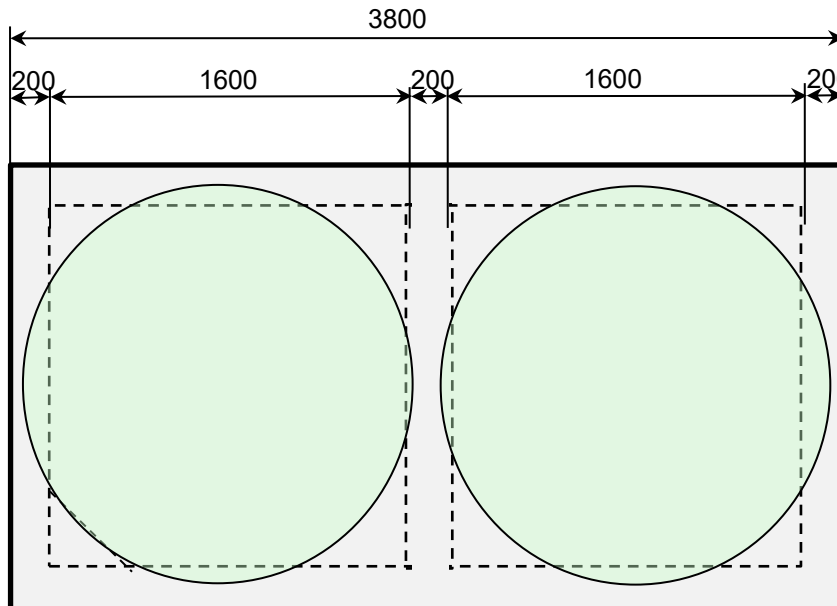
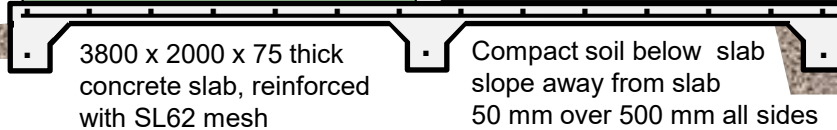
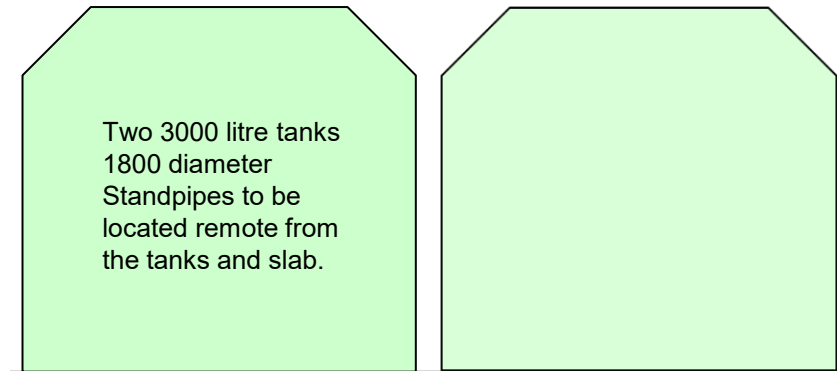

For 1 cubic metre (1 m³) of 20 MPa concrete

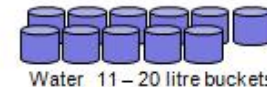
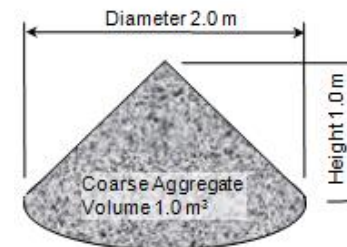
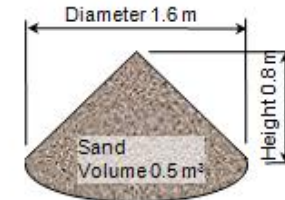

Typical Tank and Pipe Arrangement for Dual Supply

This is a typical arrangement where a local potable roof supply (blue) is used to supply a potable water standpipe (blue) and to augment a normally non-potable supply (green) from a remote dam and associated standpipes (green).

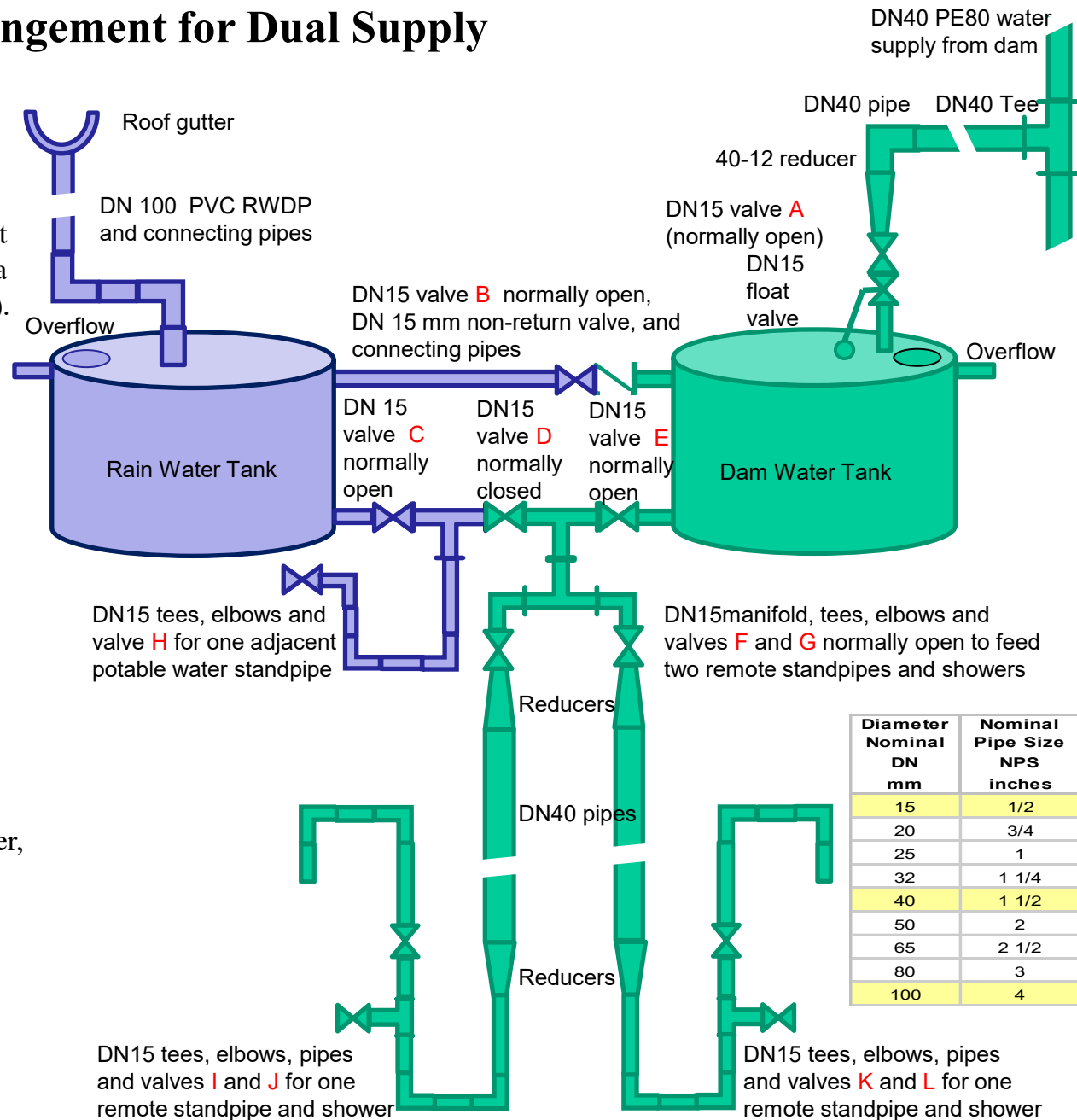

Diameter Nominal DN mm	Nominal Pipe Size NPS inches
15	1/2
20	3/4
25	1
32	1 1/4
40	1 1/2
50	2
65	2 1/2
80	3
100	4

Normal Operation

Access rain water from valve H.

Access dam water from Valves I, J, K & L.

When the Dam Water Tank is full, the float valve will close and water will flow to other tanks higher in the system.

When the Rain Water Tank is full, water will flow to the Dam Water Tank.

Maintenance

If rainwater is not available, the Rain Water Tank can be used as extra storage of dam water, by closing Valve H and opening Valve D.

To isolate the rain water tank (for maintenance), close Valves B and C and open Valve D.

To isolate the dam water tank (for maintenance), close Valves B and E and open Valve D.

Solomon Islands Rural Water Supply, Sanitation and Hygiene



THE SOLOMON ISLANDS RURAL WATER SUPPLY, SANITATION & HYGIENE DESIGN AND CONSTRUCTION STANDARDS

Technical requirements for rural WASH
Projects

Version 2, Nov 2015



The Rural Water Supply, Sanitation, and Hygiene Program
Environmental Health Division Ministry
of Health and Medical Services
P.O. Box 349
Honiara, Solomon Islands
Phone: 28105

Solomon Islands Rural Water Supply, Sanitation and Hygiene

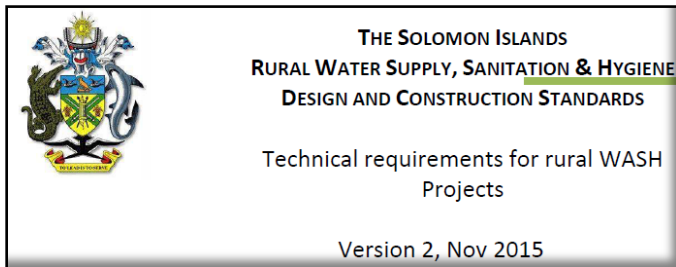

Contents

FOREWORD

ACKNOWLEDGEMENTS

VERSION HISTORY

ABBREVIATIONS & DEFINITIONS

INTRODUCTION

CONTENTS

1. GENERAL INFORMATION

- 1.1 Location and Population
- 1.2 Geography
- 1.3 Climate
- 1.4 Community aspects
- 1.5 Health statistics

2. LEGISLATION

- 2.1 Introduction
- 2.2 The Environment Act (1998) and Environment regulations 2008
 - 2.2.1 General
- 2.3 Key sections:
 - 2.3.1 Summary
- 2.4 Environmental Health Act (1996)
 - 2.4.1 General
 - 2.4.2 Key sections
 - 2.4.3 Summary
- 2.5 River waters Act (1996)
 - 2.5.1 General
 - 2.5.2 Key sections
- 2.6 The Rural WASH Policy (2014)
- 2.7 Solomon Islands Water Authority Act (1996)
- 2.8 Provincial ordinances

3. SURVEY & DESIGN

- 3.1 Indicators
- 3.2 Guidance notes
- 3.3 Survey requirements
- 3.4 Design requirements
 - 3.4.1 Design period
 - 3.4.2 Population growth
 - 3.4.3 Flow measurement
 - 3.4.4 Safe yield
 - 3.4.5 Design flow
 - 3.4.6 Storage tanks
 - 3.4.7 Residual head
 - 3.4.8 Software

4. SANITATION

- 4.1 Indicators
- 4.2 Guidance notes
- 4.3 Toilet construction standards:
 - 4.3.1 Common standards
 - 4.3.2 Basic pit latrine
 - 4.3.3 Raised pit
 - 4.3.4 VIP Latrines

- 4.3.5 Water-sealed toilets
- 4.3.6 Septic tanks
- 4.3.7 Compost toilets
- 4.3.8 Sanitation selection chart

5. RURAL WATER SUPPLY

- 5.1 Indicators
 - 5.1.1 Water Quantity
 - 5.1.2 Access
 - 5.1.3 Water quality
- 5.2 Guidance notes
- 5.3 Piped water supply system components
 - 5.3.1 Intake
 - 5.3.2 Pipes
 - 5.3.3 Water holding receptacles
 - 5.3.4 Tap stands & showers
 - 5.3.5 Suspended & road crossings
 - 5.3.6 Pump house
 - 5.3.7 Sedimentation tank
- 5.4 Hand-dug wells and boreholes
- 5.5 Pumps
- 5.6 Rainwater Harvesting
- 5.7 Other
 - 5.7.1 Concrete

6. WATSAN FOR PERSONS WITH SPECIAL NEEDS

- 6.1 Indicators
- 6.2 Guidance Notes:
 - 6.2.1 Introduction
 - 6.2.2 Policy
 - 6.2.3 Approach
- 6.3 Standards
 - 6.3.1 Sanitation
 - 6.3.2 Water supply

7. WASH IN CLINICS

- 7.1 Indicators
- 7.2 Guidance Notes
- 7.3 WASH Infrastructure for health facilities:
 - 7.3.1 Sanitation
 - 7.3.2 Water supply
 - 7.3.3 Water quality
 - 7.3.4 Waste disposal
 - 7.3.5 Waste disposal design parameters

8. APPENDIX 1: RAINFALL DATA

9. APPENDIX 2: DESIGN REPORT FORMAT

10. APPENDIX 3: TOOL LIST

Water Quality

5.1.1 Water Quantity

To ensure that sufficient water is available to all users, the following basic water quantities are to be supplied:

Table 3: Water demand design standards

Category	Quantity	Description
community	5 l/p/d	Minimum for rainwater harvesting projects when other water sources are available. Due to the very high (relative) costs for RWC projects, minimum water demand is set at 5 l/p/d in line with WHO standard for minimum drinking quantity
	20 l/p/d	Absolute minimum for any water supply system. If rainwater is the only viable source, this minimum amount must be met with rainwater storage. If a source cannot provide this minimum, it should be supplemented with rainwater storage
	50 l/p/d	WHO minimum for rural communities. Can still be used if 100l/p/d cannot be supplied by the source but will require extra community expectation setting
	100 l/p/d	The standard for rural communities

Access

5.1.2 Access

To ensure easy access to water points, the following applies:

- Service a preferred maximum of 5 households per public tap stand;
- Water points are at suitable height for the users to encourage them to use water as often as required.
- Be at a preferred maximum distance of 100m of the users, but no more than 200m;
- Water points are at a suitable height for the users to encourage them to use water as often as required.

Water Quality

5.1.3 *Water quality*

There are no specific Solomon Islands water quality standards available, instead WHO guidelines are used.

Two laboratories are available for water testing, at the National Public Health Lab and at the Solomon Water. The limited number of testing facilities and limited resources in general makes it impossible to test every water source used or considered for use.

A number of portable biological testing kits are available in SI where these are used this is considered acceptable. However, the test kits should only be used by staff trained in both sample collection and use of the kits. For Further information, contact the national public health laboratory.

Water quality is therefore primarily dealt with in response to issues (specifically checking both local knowledge for reports of illness and medical professionals dealing with people from the location). This is especially important when looking for potential chronic disease causing elements such as heavy metals these investigations should direct any specialist testing required.

A basic sanitary survey of the (potential) water source and the use of H₂S⁴ testing are highly recommended at the initial development stage of a project. They are required when responding to suspected water quality issues and if results indicate serious problems, full water quality testing must be done in one of the available laboratories.

Water quality cannot be guaranteed in rural settings in the current conditions.

Guidance Notes

5.2 Guidance notes

Definition

Water supply is defined here as any facility that provides a source of water. The various types of water supply in rural the Solomon Islands are⁵:

- *Direct Gravity Fed (DGF)*: a facility where an uphill source is dammed or tapped into and the water is transported using gravity to the users;
- *Indirect Gravity Fed (IGF)*: a facility where a pump is used to pump water to an overhead storage tank from which the water gravity feeds to the users;
- *Hand pumps (HP)*: a facility where water is manually pumped up from a borehole, a hand-dug well, an underground storage tank or other. RWASH recommends a version of the Blair hand pump called the Solomon Hand pump (Sol Mark), the India mark II or Rope and washer pump;
- *Hand-dug wells*: a facility where the groundwater is reached by digging a well. Water in most cases in the Solomon Islands is extracted using a bucket. Wells are often lined with drums, rocks, timber or concrete;
- *Rainwater harvesting (RWC)*: a facility where rainwater is collected and stored in a tank. In the Solomon Islands, only roofs are used as catchment areas.

Accurate data on coverage with water systems are not available however it has been estimated at 70%. This figure does not distinguish the state of operation of the systems however; only an estimated 30% of the population have functioning built water systems with the remainder of the 70% reporting water supplies that are not functional.

Most water supplies are gravity fed systems. These systems use public tap stands - household connections are seldom found. DGF systems can provide a large quantity of water, are easy to construct, operate and maintain, and are cheap relative to the service provided (in terms of water quantity/user/day). Land ownership issues can play a role however.

Rainwater harvesting is the second most common type of water supply. RWC systems are easy to construct and maintain but are relatively expensive, as water quantity per person per day is limited.

Hand pumps the least common type of system. Spare parts are difficult to get and systems break down fairly quickly. As wells are usually located within the village, the potential for polluting the water source is generally higher than with other systems. Hand pump systems can provide a good level of service however.

IGF systems are not very common in the Solomon Islands, as the funds and skills required for operation and maintenance (O&M) are often beyond the capacity of a community. High initial investment costs are a further barrier. Pumped water supplies are recommended only for public institutions (schools, hospitals etc.), which usually have personnel and funds available for maintenance.

Significant interest has been shown in recent years on solar pumped systems which are stated to be low or zero maintenance. These require specific design to ensure that the yield and head meet the needs for the system, it is important that the project leaves behind the capacity to carry out or procure problem solving and repairs. Where zero maintenance (disposable pumps) systems are selected the project will need to address how replacement costs will be raised.

The selection of the type of system depends on numerous factors, including user preference, suitability of existing water sources, land ownership issues, geology, and topography.

Climate Change

Climate change

Effects of climate change will be particularly noticed in changes in the water cycle. Increasingly unpredictable rainfall will lead to less predictable water flows and recharge, and more droughts and floods.

As with sanitation, the potential resilience of water supply technologies can be classified as high, medium or low. Highly resilient technologies should function under most expected climate change conditions, medium resilient under a significant number of climate conditions, and low under a restricted number of conditions.

The most common type used in the Solomon Islands, piped water supplies, are inherently highly vulnerable to climate change effects due to its size and complexity. Piped supplies are exposed to multiple threats, starting at the source, through treatment systems (if applied) and the distribution network. The network may cross many different environments with significant hazards, and may have numerous joints that are vulnerable to leakage. Proper design, construction, leakage detection, and choice of materials contribute to the reduction of the vulnerability.

Protected springs (with the exception of artesian springs) have low-medium resilience to climate change effects, as they cannot be relocated and have limited adaptability in design

Water quality may be adversely affected by increased rainfall, or flow may be reduced in drying environments.

Boreholes are highly resilient to most climate change impacts but are less resilient to saline intrusion from rising sea levels. Drying environment may make boreholes less viable (deepening is not always possible or economically viable), especially where motorized pumping is used.

Hand-dug wells are highly vulnerable to reducing quantity of water and contamination following rainfall (ingress of water along the upper parts of the lining). Securing year-round supply is in many cases already problematic.

Rainwater harvesting rarely provide enough water throughout the year already and increased but less frequent rain or reduced rainfall makes the technology very vulnerable. Often systems are difficult to relocate and have limited adaptability in design.

Boreholes then are the only technology with high resilience to climate change effects. However, they are not universally applicable in the Solomon Islands and are relatively expensive to construct. Motorised pumping is usually outside the management capacity of the recipient community, leaving hand pumps as the more appropriate solution. Hand pump programs in the Solomon Islands have seen only limited success.

To mitigate the effects of climate change, it is recommended to provide a backup water supply in addition to the primary one. For example, another spring may be protected for use when the primary spring fails.

Communal rainwater harvesting may be added to for example a piped water supply or hand-dug well project.

As the Solomon Islands continue to prepare for climate change, the above approach should be applied in those areas identified as highly prone to climate related hazards.

All projects should include in their design report consideration of vulnerability to climate change and options for adaptation

Water Demand

Water demand

The water demand design standard for villagers has been increased from 80 l/p/d to 100 l/p/d.

This

allows for increased domestic use, as well as water use for small-scale commercial activities (i.e.: guesthouses), and some sanitation options.

Any organisation, private enterprise or individual involved in water supply projects aiming to cover a full community, must use the minimum standards as shown in Table 3 above.

For communities, the design standard of 100 l/p/d must be used at all times except where a water source cannot deliver the required quantity. In that case, the WHO standard of 50 l/p/d may still be applied. Where this option is followed extra allowance will need to be made for education of the community on the implications of this decision.

The amount of 20 l/p/d represents the minimum quantity of water at which people experience a minimum level of comfort with regards to water availability (based on empirical findings around the world). This standard should only be used when water availability is severely restricted and may only be selected with the approval of the chief engineer

Table 3: Water demand design standards

Category	Quantity	Description
community	5 l/p/d	Minimum for rainwater harvesting projects when other water sources are available. Due to the very high (relative) costs for RWC projects, minimum water demand is set at 5 l/p/d in line with WHO standard for minimum drinking quantity
	20 l/p/d	Absolute minimum for any water supply system. If rainwater is the only viable source, this minimum amount must be met with rainwater storage. If a source cannot provide this minimum, it should be supplemented with rainwater storage
	50 l/p/d	WHO minimum for rural communities. Can still be used if 100l/p/d cannot be supplied by the source but will require extra community expectation setting
	100 l/p/d	The standard for rural communities

Piped Water Supply - Intake

5.3.1 Intake

The intake structure shall:

- Have the intake pipe secured in reinforced concrete, reinforced concrete blocks, stones, masonry or rock piles;
- Be suitably covered where possible (i.e. at a spring), either with concrete or roofing iron; when a concrete cover is used, suitable access and ventilation must be provided for;
- Use galvanized iron pipes and fittings;
- Be fitted with a control/gate valve;
- Have screened inlet piping;
- Be fitted with a washout placed at floor level, not smaller than 80mm diameter, and of suitable length to avoid erosion near the intake;
- Include provisions to prevent access to the intake structure by animals (fencing of minimum 5m around the source);
- Include surface runoff diversion where possible;
- Include flood prevention measures where possible;
- The outlet pipe must be a minimum of 15cm above the floor of the intake structure;
- Where possible, have the inlet pipe 3 pipe diameters below the water surface;
- Have the crest of the dam, or the overflow, below the height of the natural water level to avoid backflow;
- Provide for sufficient overflow capacity to ensure scour and damage to the structure is avoided
- Include a sedimentation and/or filtration facility for water sources with high sediment loads;

Pipes

5.3.2 Pipes

All pipes shall:

- Be made of high density polyethylene (HDPE), where pipes can be buried and
- Be for HDPE pipes of AS/NZS 4130-1997, SDR 17 or equivalent ISO standard or
- be for GI pipes of AS 1074-1989, AS/NZS 4792-2006 or equivalent ISO standard;
- The maximum diameter is 90mm to avoid difficulties with maintenance and installation (specialized tools required, difficult to tighten large fittings, availability of spare parts). If need be, the design flow can be reduced or if that is not possible, an alternative source must be found);
- Not be rated to less than class9 (PN9), or 90m water head (see also paragraph 3.2.5: residual water head);
- Be buried to least 300mm cover from the top of the pipe where possible, in trenches devoid of sharp objects, stones or large quantities of organic material. The trench should allow sufficient space on either side of the pipe to ensure that pipe is not punctured by any sharp objects in the surrounding ground during installation;
- Be made of galvanized iron (GI) where pipes cannot be buried underground, are used for tank inlets, outlets or intake box fittings, or are placed on the side or in a river/creek/ stream bed;
- Not be made of polyvinyl chloride (uPVC), with exceptions of uPVC pipes used for tapstand supports, downpipes, intake washouts and tank overflows;
- Include washout valves at low points in the pipeline, protected by a cover;
- Consider the potential of air trapped inside; Where local high points are included either air flushing points should be included or design should include assessment to ensure supercritical flow rates are regularly achieved. (note that automatic air release valves are not recommended due to maintenance and supply chain limitations)
- High-pressure fittings must be used at all times, of the same quality standards as the pipes. A union shall be used for every three lengths of GI pipe or less, before t- offs, valves or other types of fittings or where the pipeline changes direction. Universal couplings or Gibault joints may also be used.
- Include a GI union for every GI pipe joint where the water source contains a lot of lime stone. GI pipes should be designed one size larger to allow for possible lime stone growth inside the pipe;
- Have all major branch lines fitted with an isolation valve;
- Include gate valves on tap branch lines if excessive pressure is an issue;
- Incorporate valves of AS 2638.1-2002 or Equivalent ISO standard.

Tanks

5.3.3 Water holding receptacles

All water holding receptacles shall:

- Be made of plastic, fiber-glass, metal (with or without liner), reinforced masonry, or ferro-cement; the latter being the preferred option⁶;
- Have a strong and secure cover with a manhole to allow access or alternative means to clean the inside;
- Be of functional and water tight design;
- Include a system to extract the water without contaminating it;
- have appropriate connections for inlet and outlet fittings;
- Have all openings vermin proof;
- use GI fittings for the inlet and outlet;
- Have float valves for all tanks in a gravity fed system;
- Be fitted with an overflow of sufficient size, 2x the size of the inlet, allowing excess water to drain away from the immediate tank surroundings (>3m); uPVC pipes may be used for the overflow; (where prefabricated tanks mean no overflow is possible then design must ensure no risk of scour or standing water around the tank).
- Be placed on a reinforced concrete base slab of sufficient thickness, on a tank stand or other sufficient measure to prevent roots from damaging the tank;
- Incorporate the effects of seismic activity into the design, construction, placement and/or anchoring where applicable
- Not have any fittings protruding through the base slab;

Tanks may be constructed above or underground according to user preference.

Standpipes

5.3.4 Tap stands & showers

Tap stands shall:

- Be constructed at locations accessible to all community members:
- Incorporate a reinforced slab of sufficient size
- Be sited in consultation with users;
- Have taps high enough to prevent dogs contaminating the faucet (normally 1m will be adequate for this)
- Include appropriate drainage facilities (dependent on local soil conditions i.e. sandy soil, - simple soak pit, clay – to natural open drain) to prevent mosquitos from breeding in the vicinity of the tap stand; where water is drained away from the water point, the length of the drainage channel is at least 3m and has a minimum slope of 5%
- Be constructed using GI pipes of sufficient diameter (3/4" minimum) to withstand daily use, and include concrete or masonry support of the stand pipe; (unless an alternative mechanism is provided for rigidity at least equal GI and approval sought from the Chief Engineer)

Showers shall:

- Only be constructed where the water availability exceeds 50l/p/d, and residual head exceeds 5m;
- Constructed only after consultation with the community of pros and cons of showers;
- Be combined with the tap stand in one unit, conforming to the Solomon Island normal practice;

Ferro-cement tanks are relatively the cheapest, durable and easy to pair but require good skills to properly construct. Plastic and fiberglass are relatively expensive but are easy to install. Fiberglass tanks can be fairly easily repaired, plastic tanks not really. Metal tanks are expensive, require medium amount of skills to install, and are prone to rusting

Water Treatment

This section of the training package is to provide an very brief insight into water treatment for large population centres and cities. It is for background information only, and is not intended as a substitute for formal training in water treatment and distribution, or detailed design of systems and components.

Water Treatment for Large Populations

This section of the training package is to provide an very brief insight into sewage and waste water treatment for large population centres and cities. It is for background information only, and is not intended as a substitute for formal training in waste water treatment and sewage systems, or detailed design of systems and components.

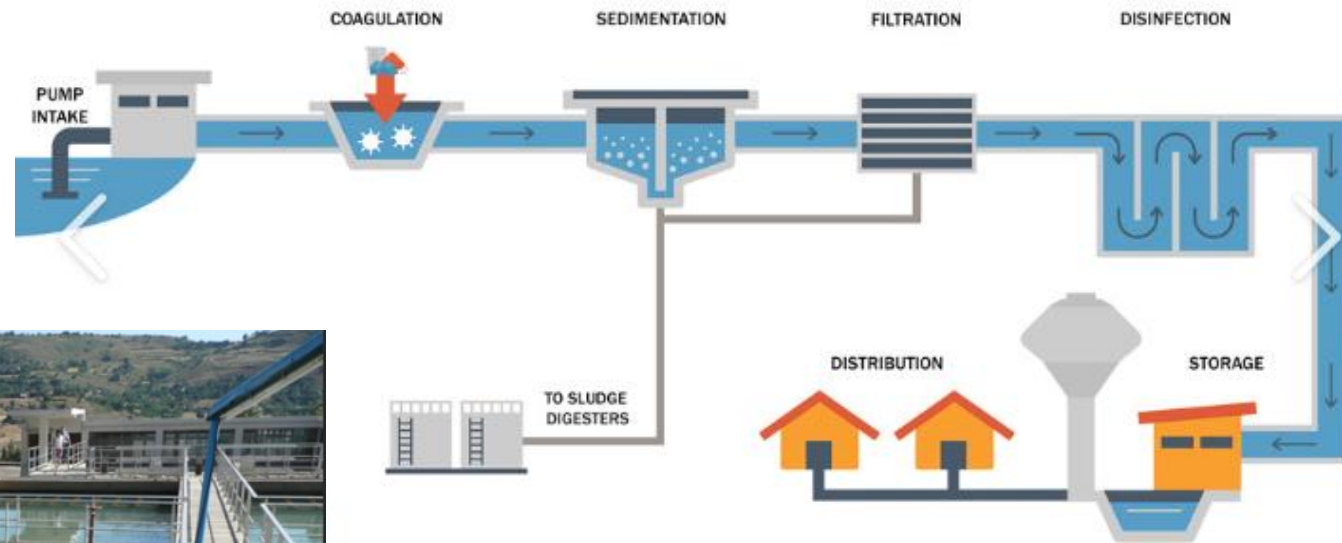

Package Water Treatment

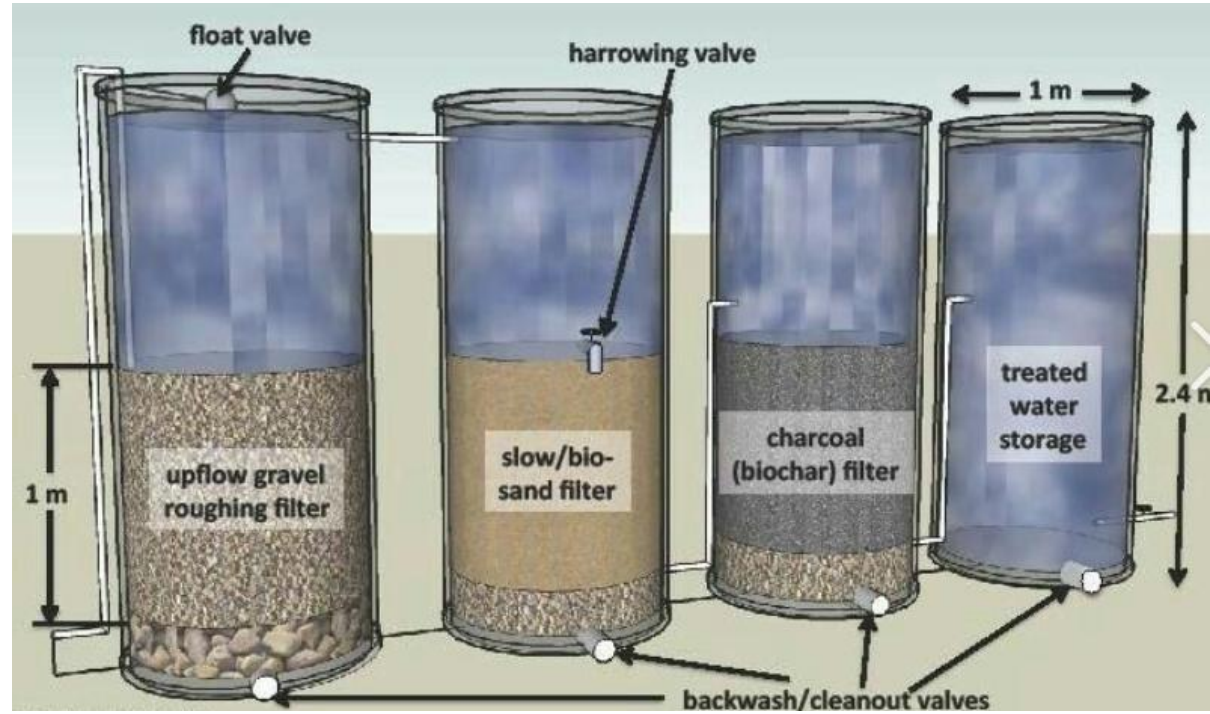

Assignment

Please complete your name, email address and postal address; and answer the following questions using the notes in this workbook. Submit this page to the tutor, or email this page to RodJohnstonAUS@gmail.com. The tutor will assess it and reply with comments and will complete the Training Certificate.

Name: _____ Email: _____

Postal Address: _____

1. Is a tank necessary? _____ If so, show plumbing _____

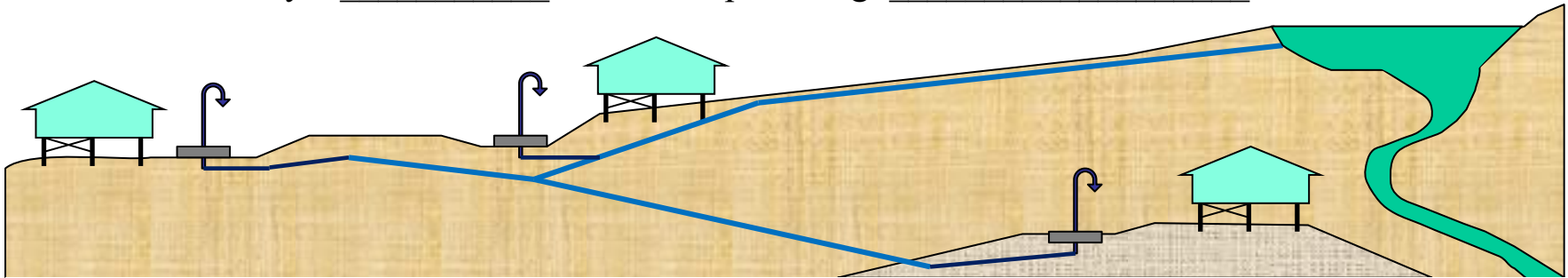

2. What is the correct mix for normal concrete (20 MPa [megapascals])?

40 kg bags portland cement _____ m³ sand _____ m³ gravel _____ litres water









3. List the materials required for a standpipe _____

Training Certificate

I hereby certify that

has completed course material in

*Rural Water Supply Training – Introductory Level
prepared by Quasar Management Services Pty Limited.*

Signed:

Name:

Date:



Quasar Management Services Pty Limited
ABN 21 003 954 210
Not-for-profit consulting structural and civil engineer
Subsidiary of Partner Housing Australasia (Building) Incorporated
69 Renwick Street, Redfern NSW 2016, Australia
Phone: +61 432 611 550
Email: RodJohnstonAUS@gmail.com

This certificate is valid only if signed and dated by an authorised officer of Quasar Management Services Pty Limited.

Disclaimer & Copyright

Disclaimer

This training package covers broad engineering principles and building practices, with particular emphasis on village infrastructure in the Asia-Pacific region. These broad principles and practices must be translated into specific requirements for particular projects by professional architects, engineers or builders with the requisite qualifications and experience. Associated sample specifications and drawings are available in electronic format, with the express intention that architects, engineers and builders will edit them to suit the particular requirements of specific projects. The design, construction and costing of structures must be carried out by qualified and experienced architects, engineers and builders, who must make themselves aware of any changes to the applicable standards, building regulations and other relevant regulations. The authors, publishers and distributors of these documents, specifications and associated drawings do not accept any responsibility for incorrect, inappropriate or incomplete use of this information.

Copyright

© Quasar Management Services Pty Ltd All rights are reserved. Permission is given for individuals to use this material in the preparation of designs, specification and contracts for individual projects. Permission is also given for not-for-profit Nongovernmental Organizations to use this material in the preparation of Building Skills Training Programs and for the design, specification and construction of affordable housing and associated infrastructure in the Asia-Pacific region. Use of this material for any other commercial purposes prohibited without the written permission of the copyright owner.